

2132 and 2116 PID Temperature Controllers



**EUROTHERM
CONTROLS**

Installing and Operating Instructions

Thank you for choosing the 2132 or 2116 Temperature Controller. Supplied in 1/32 and 1/16 DIN panel sizes they are designed for accurate, stable control of ovens, chillers, sterilisers and other heating and cooling processes. Two outputs are configurable for heating, cooling and alarms.

The controller is supplied configured according to the order code given on page 11. Check this on the side labels to determine the configuration of your particular controller.

This controller meets the European Directives on safety and EMC.

DIMENSIONS AND INSTALLATION

Model 2132

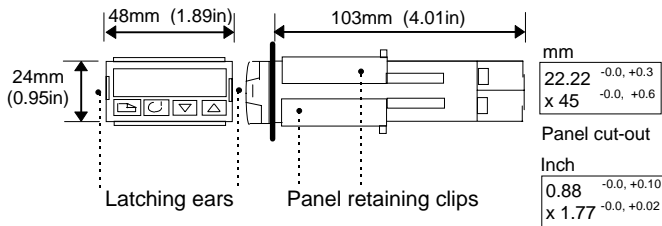

Model 2116

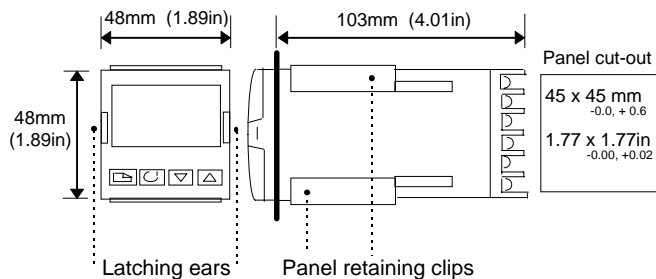

To Install the Controller

Please read the safety information on pages 11 & 12 before proceeding.

1. Prepare the panel cut-out to the size shown
2. Insert the controller through the cut-out.
3. Spring the panel retaining clips into place. Secure the controller in position by holding it level and pushing both retaining clips forward.
4. Peel off the protective cover from the display

Unplugging the Controller

The controller can be unplugged from its sleeve by easing the latching ears outwards and pulling it forward out of the sleeve. When plugging it back into its sleeve, ensure that the latching ears click back into place to maintain the IP65 sealing.

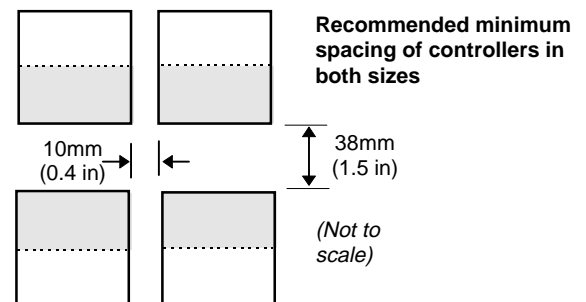

ELECTRICAL CONNECTIONS

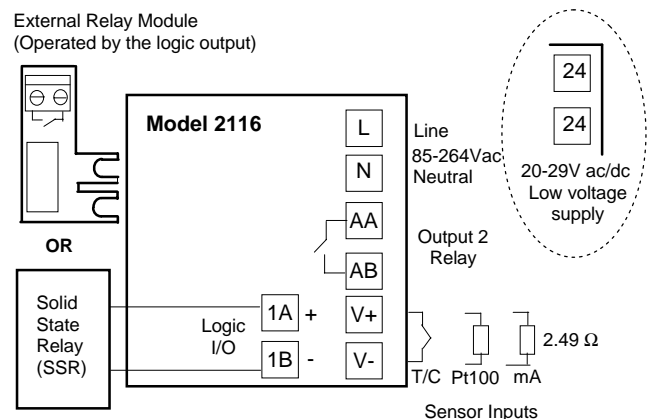
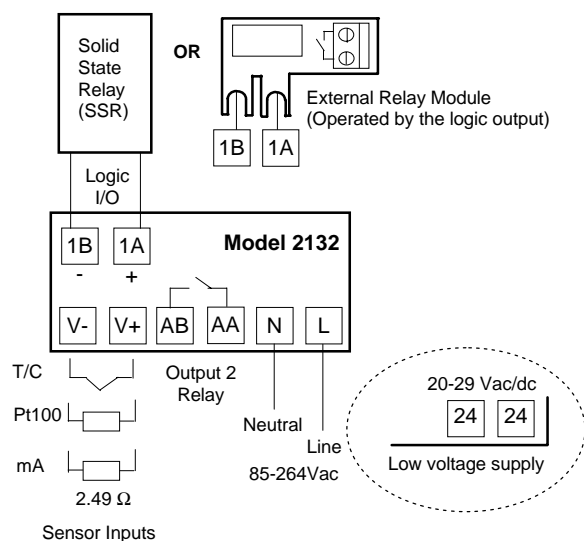

Output ratings

Logic Output: 9Vdc, 12mA (non-isolated from sensor input).
Used for: Heating, Cooling or Alarm.

Relay Output: 2A, 264V ac resistive.
Used for: Heating, Cooling or Alarm.

Contact Closure Input (replaces Logic Output).
Used for: Alarm Acknowledge or Timer start/reset

Wire Sizes

The screw terminals accept wire sizes from 0.5 to 1.5 mm (16 to 22AWG). Hinged covers prevent hands or metal making accidental contact with live wires. The rear terminal screws should be tightened to 0.4Nm (3.5lb in).

Typical Wiring Diagram

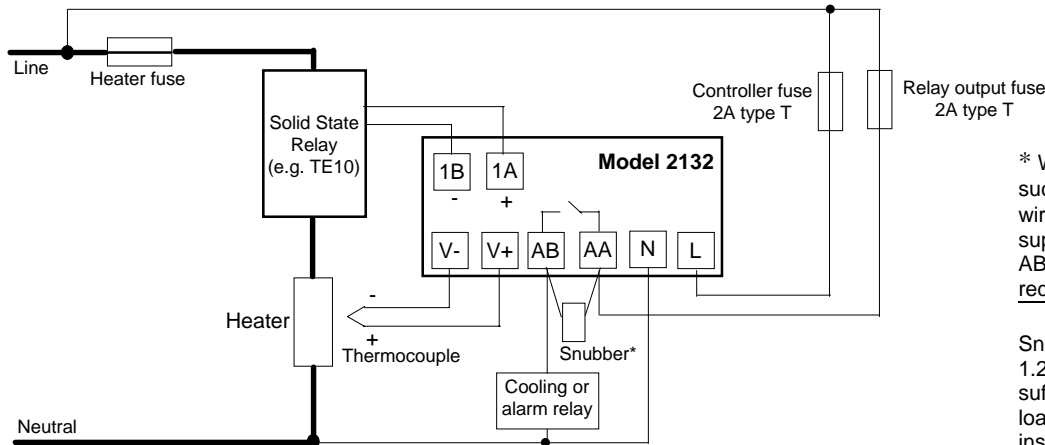

* When switching inductive loads such as contactors or solenoid valves, wire the 22nF/100Ω 'snubber' supplied across relay terminals AA & AB. This will prolong contact life and reduce interference.

WARNING

Snubbers pass 0.6mA at 110V and 1.2mA at 230Vac, which may be sufficient to hold on high impedance loads. Do not use in these installations.

OPERATION

Switch on the controller. Following a 3 second self-test sequence, you will see the display shown below. It is called the HOME display.

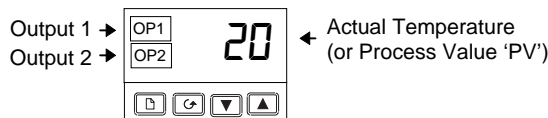

OP1 illuminates when the logic output is ON (normally heating).

OP2 illuminates when the relay output is ON (normally cooling or alarm).

If **OP1** or **OP2** are configured as alarm outputs (instead of heating and cooling), they will flash when a new 'unacknowledged' alarm occurs and go steady when the alarm is acknowledged but still true.

TO ACKNOWLEDGE A NEW ALARM

Press **[D]** and **[G]** together. This will also reset any latched alarms that are no longer true.

ALARM MESSAGES

If an alarm occurs a message will be flashed in the display. This alternates with the measured temperature as shown below:

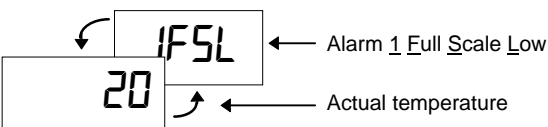

All of the possible messages are shown in this table.

Possible messages	
-FSH	Alarm - Full Scale High
-FSL	Alarm - Full Scale Low
-dEU	Alarm - Deviation
-dHi	Alarm - Deviation High
-dLo	Alarm - Deviation Low
Sbr	Sensor Break
Lbr	Loop Break
LdF	Load Fail
End	End of Timing

In place of the dash the alarm number is shown - Alarm 1 or 2 or 3.

TO ADJUST THE REQUIRED TEMPERATURE (SETPOINT)

Press and release quickly the **[V-]** or **[V+]** button. The setpoint will be displayed for 2 seconds.

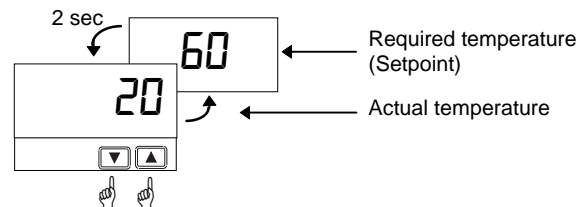

Press and hold **[V+]** to raise the setpoint

Press and hold **[V-]** to lower the setpoint

TO VIEW THE DISPLAY UNITS

Press and release quickly the **[D]** or **[G]** button. The display units will be flashed for 0.5 sec.

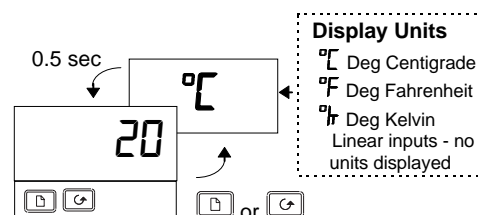

If you get lost, pressing **[D]** and **[G]** together will always return you to the HOME display.

If, at any time, no key is pressed within 45 seconds, the display will always return to the HOME display.



TO VIEW THE OUTPUT POWER

Do this if you want to see how much heating or cooling energy is being demanded by the controller. Note: This is not a measure of actual power.

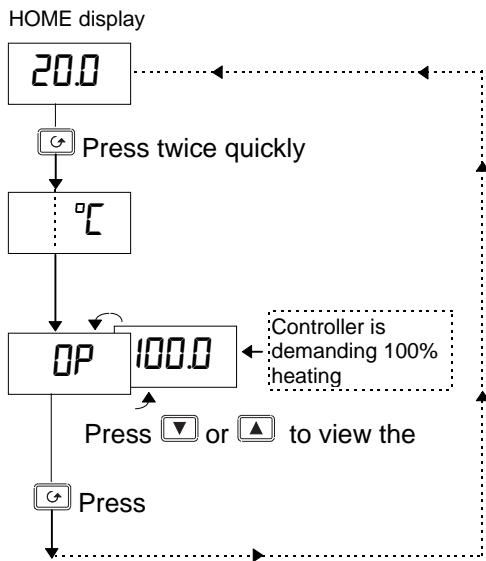

Warning!

In manual standby mode (see 'To Use The Timer') the output power can be adjusted by the operator, causing heating or cooling to be permanently applied. To prevent this make the OP parameter read only (see 'To Hide, Reveal And Promote Parameters')

TO SELECT OR CHANGE OTHER PARAMETERS

Parameters are settings in the controller which you can change to suit the process. They are found under list headings.

Press the button to step through the list headings as shown below.

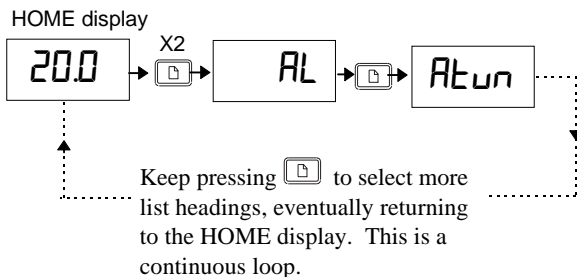

Turn to page 4 to see all of the list headings.

These lists are used to:

- Change alarm setpoints
- Tune the controller to the process
- Manually select PID values
- Change setpoint limits and access the in-built timer
- Change input and output limits

TO ADJUST THE ALARM SETPOINTS (TRIP LEVELS)

Alarm setpoints are found under the AL list.

Press twice to choose the AL list.

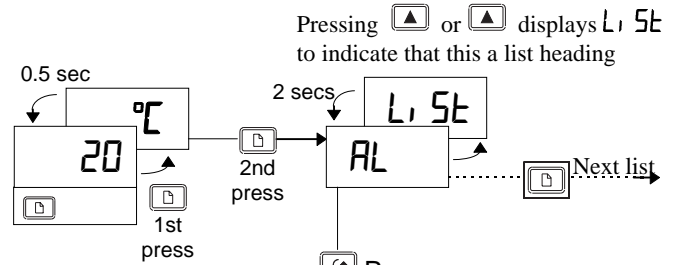

There are three alarm setpoints. The first character is the alarm setpoint number, the next three the alarm type, as follows:

- FSL Low alarm
- FSH High alarm
- dEU Deviation
- dHi Deviation High
- dLo Deviation Low

If an alarm has been disabled, it will not appear in this list.

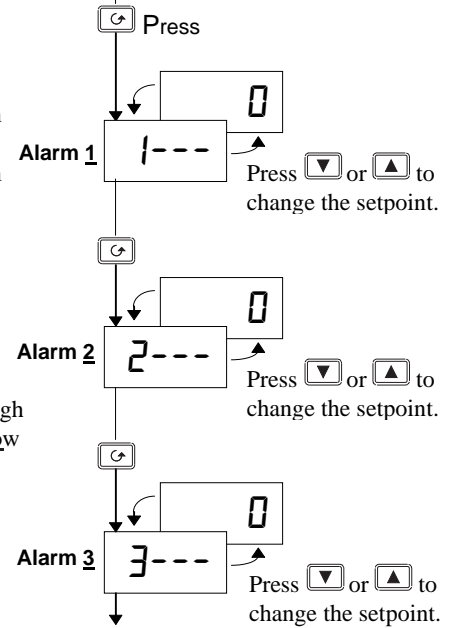

Press and together to return to the HOME display.

Note: The other parameters listed on pages 4 and 5 are accessed and adjusted in exactly the same way as this example.



PARAMETER LISTS

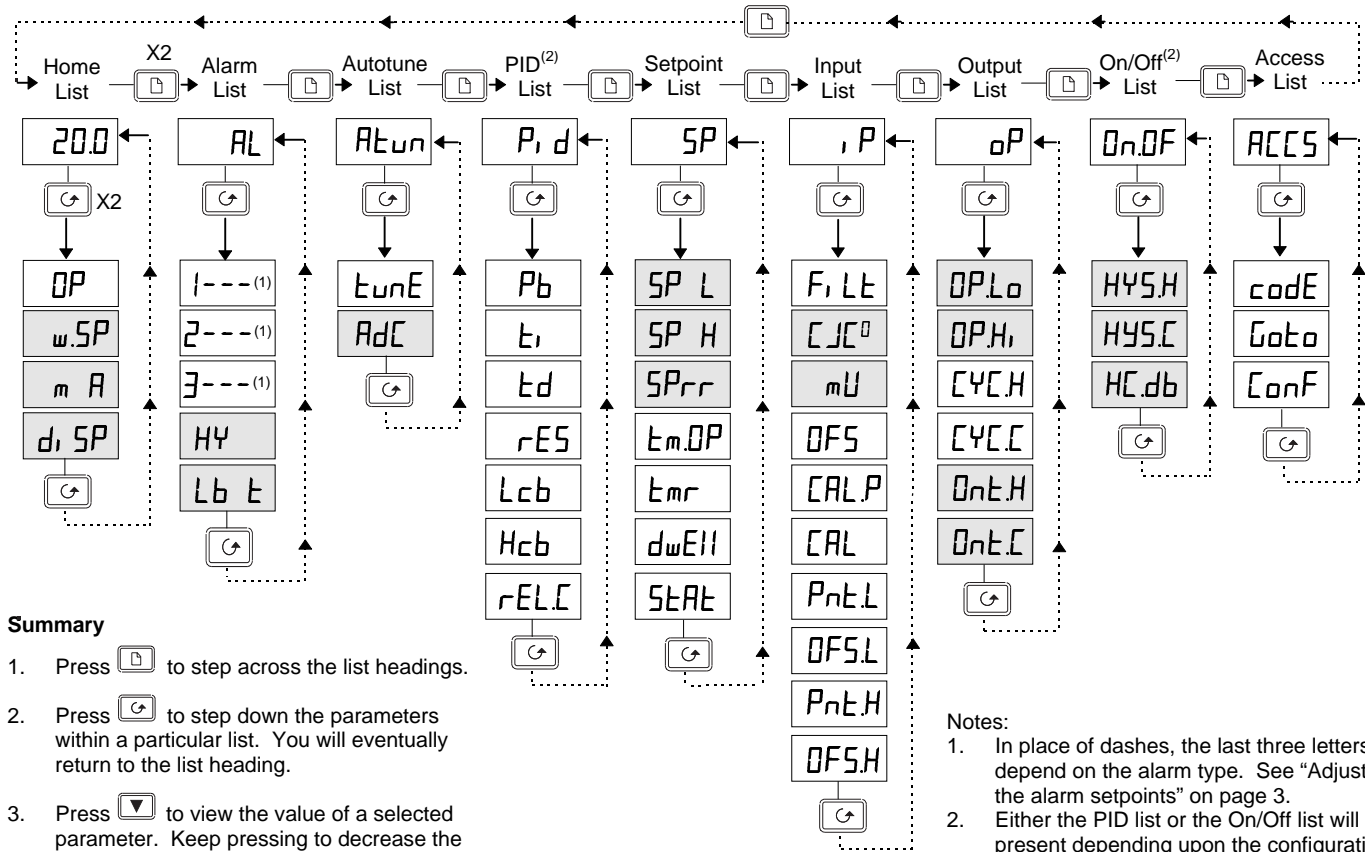

Summary

1. Press to step across the list headings.
2. Press to step down the parameters within a particular list. You will eventually return to the list heading.
3. Press to view the value of a selected parameter. Keep pressing to decrease the value.
4. Press to view the value of a selected parameter. Keep pressing to increase the value.

Notes:

1. In place of dashes, the last three letters depend on the alarm type. See "Adjusting the alarm setpoints" on page 3.
2. Either the PID list or the On/Off list will be present depending upon the configuration of the controller.

Shaded boxes are hidden when shipped from the factory. To reveal see "To Hide, Reveal and Promote Parameters" on page 6.

Parameter Tables

	Home List	Adjustable Range	Default setting	Customer setting
	<u>Output Power</u> demand in %	-100 = max cooling, 100.0 = max heating.		
	<u>Working Setpoint</u>	Only appears when setpoint rate limit enabled	Read only	Read only
	<u>Manual/Auto</u> Select	<i>Auto</i> <u>Automatic</u> control selected <i>mAn</i> <u>Manual</u> standby selected	<i>Auto</i>	
	Home <u>Display</u> Options	<i>Std</i> <u>Standard</u> - Shows the process value with the setpoint accessed by pressing the and buttons. Displays the <u>output power</u> - for use as a manual station. (Only applies to software version 1.4) <i>nonE</i> <u>Blank Display</u> (only alarm messages flashed) <i>PV</i> Displays the <u>Process Value</u> only <i>ALSP</i> Displays the <u>Alarm 2 Setpoint</u> only <i>PuAL</i> Displays the <u>Process Value</u> with <u>Alarm 2 Setpoint</u> accessed by the and buttons	<i>Std</i>	

	Alarm List (See page 3)	Adjustable Range	Default Setting	Customer setting
<i>1---</i>	Alarm <u>1</u> Setpoint	In place of dashes, the last three letters indicate the alarm type: <i>-FSL</i> <u>Full Scale Low</u> <i>-FSH</i> <u>Full Scale High</u> <i>-dEv</i> <u>Deviation</u> <i>-dHi</i> <u>Deviation High</u> <i>-dLo</i> <u>Deviation Low</u>	<i>0</i>	
<i>2---</i>	Alarm <u>2</u> Setpoint		<i>0</i>	
<i>3---</i>	Alarm <u>3</u> Setpoint		<i>0</i>	
<i>HY</i>	Alarm <u>Hysteresis</u>	<i>1</i> to <i>9999</i> in display units (This value is common to all alarms) Hysteresis is used to prevent the alarm output 'chattering' by setting a difference between the alarm switch ON and switch OFF points	<i>1</i>	
<i>Lb t</i>	<u>Loop Break Time</u>	<i>OFF</i> to <i>9999</i> minutes	<i>OFF</i>	



<i>Rtun</i>	Automatic Tuning List (See page 10)	Adjustable Range	Default Setting	Customer setting
<i>tunE</i>	Automatic <u>T</u> une Enable	OFF or on	OFF	
<i>Rdc</i>	Automatic Manual reset calculation (when P+D control)	OFF or on	OFF	

<i>Pi d</i>	PID List (See page 10)	Adjustable Range	Default Setting	Customer setting
<i>Pb</i>	<u>P</u> roportional <u>B</u> and	1 to 999.9 display units	20	
<i>t_i</i>	<u>I</u> ntegral <u>T</u> ime	OFF to 9999 seconds	360	
<i>t_d</i>	<u>D</u> erivative <u>T</u> ime	OFF to 9999 seconds	60	
<i>rES</i>	Manual <u>R</u> eset Value (only present if <i>t_i</i> = OFF)	- 100 to 100.0 %	0.0	
<i>Lcb</i>	<u>L</u> ow <u>C</u> utback	<i>RuLo</i> to 999.9 display units	<i>RuLo</i>	
<i>Hcb</i>	<u>H</u> igh <u>C</u> utback	<i>RuLo</i> to 999.9 display units	<i>RuLo</i>	
<i>rELC</i>	<u>R</u> elative <u>C</u> ool Gain	0.0 1 to 9.99	1.00	

<i>SP</i>	Setpoint List (See "To Use the Timer" on page 6)	Adjustable Range	Default Setting	Customer setting
<i>SP L</i>	<u>S</u> etpoint <u>L</u> ow Limit	- 1999 to 999.9	As per order	
<i>SP H</i>	<u>S</u> etpoint <u>H</u> igh Limit	- 1999 to 999.9	As per order	
<i>SPrr</i>	<u>S</u> etpoint <u>R</u> ate Limit	OFF to 999.9 display units per minute	OFF	
<i>t_mOP</i>	<u>T</u> imer <u>O</u> perating Mode	OPt. 1 to OPt.5	OPt. 1	
<i>t_mr</i>	<u>T</u> ime <u>R</u> emaining	0 to 9999 minutes	0	
<i>dwEl</i>	<u>D</u> well Time	OFF to 9999 minutes	OFF	
<i>StAt</i>	Timer <u>S</u> tatus	OFF or on	OFF	

<i>i P</i>	Input List (See "User Calibration" on page 9)	Adjustable Range	Default Setting	Customer setting
<i>F_iLE</i>	Input <u>F</u> ilter Time Constant	OFF to 999.9 seconds	1.6	
<i>CTC°</i>	<u>C</u> old <u>J</u> unction Temperature measured at rear terminals		Read only	
<i>mV</i>	<u>M</u> illivolt Input measured at the rear terminals		Read only	
<i>OFFS</i>	Process value <u>O</u> ffset	- 1999 to 9999 display units	0	
<i>CALP</i>	<u>C</u> alibration <u>P</u> assword	0 to 9999	3	
<i>CAL</i>	User <u>C</u> alibration Enable	<i>FACt</i> Re-instates factory calibration <i>USEr</i> Re-instates user calibration	<i>FACt</i>	
<i>PnEL</i>	<u>L</u> ow Calibration <u>P</u> oint	- 1999 to 9999 display units	0	
<i>OFFS.L</i>	<u>L</u> ow Point Calibration <u>O</u> ffset	- 1999 to 9999 display units	0	
<i>PnEH</i>	<u>H</u> igh Calibration <u>P</u> oint	- 1999 to 9999 display units	100	
<i>OFFS.H</i>	<u>H</u> igh Point Calibration <u>O</u> ffset	- 1999 to 9999 display units	0	

<i>oP</i>	Output List	Adjustable Range	Default Setting	Customer setting
<i>OPLo</i>	<u>L</u> ow <u>O</u> utput Power Limit	- 100 to 100.0 %	0	
<i>OPHi</i>	<u>H</u> igh <u>O</u> utput Power Limit	- 100 to 100.0 %	100.0	
<i>CYCH</i>	<u>H</u> eating Output <u>C</u> ycle Time	0.2 to 999.9 seconds	1.0 Lgc 20 Rly	
<i>CYCL</i>	<u>C</u> ooling Output <u>C</u> ycle Time	0.2 to 999.9 seconds	5.0 Lgc 20 Rly	
<i>onEH</i>	<u>H</u> eating Output Minimum <u>O</u> n Time	<i>RuLo</i> to 999.9 seconds (Auto = 50ms)	<i>RuLo</i>	
<i>onEL</i>	<u>C</u> ooling Output Minimum <u>O</u> n Time	<i>RuLo</i> to 999.9 seconds (Auto = 50ms)	<i>RuLo</i>	

<i>onOF</i>	On Off Output List	Adjustable Range	Default Setting	Customer setting
<i>hYS.H</i>	<u>H</u> eating <u>H</u> ysteresis	1 to 9999 display units	1	
<i>hYS.C</i>	<u>C</u> ooling <u>H</u> ysteresis	1 to 9999 display units	1	
<i>HCdb</i>	<u>H</u> eat/ <u>C</u> ool <u>D</u> eadband	0 to 9999 display units	0	

<i>ACC5</i>	Access List (See "To Hide, Reveal and Promote" parameters on page 6)	Adjustable Range	Default Setting	Customer setting
<i>cadE</i>	Access Pass Number	0 to 9999	1	
<i>GoLo</i>	Go To Required Access Level		<i>OPt. r</i>	
<i>ConF</i>	Configuration Pass Number	0 to 9999	2	



TO HIDE, REVEAL AND PROMOTE PARAMETERS

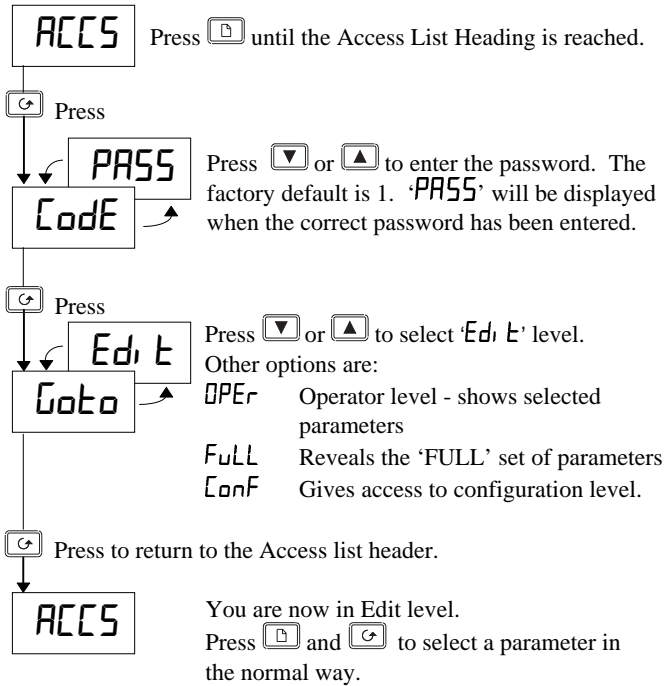

Example:

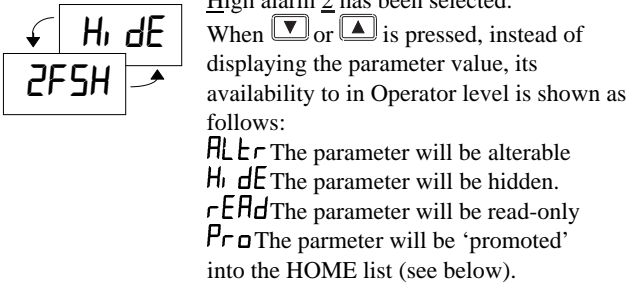

The **PrO** (Promote) option

Up to twelve commonly used parameters can be 'promoted' into the HOME list. This will give the operator quick access to them by simply pressing the button. This feature, used in combination with 'hide' and 'read only', allows you to organise the way in which you want your controller formatted.

Example:

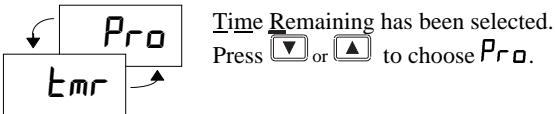

The parameter **tmr** will now appear in the HOME list. Repeat the procedure for any other parameters you wish to promote.

To remove a parameter go to **Edit** level, select the parameter from the relevant list and change the choice from **PrO** back to **ALtEr**, **rEAd** or **Hi dE**.

Returning to Operator level

Repeat the above procedure for all the parameters you wish to hide, promote, or make read-only then return to operator level:

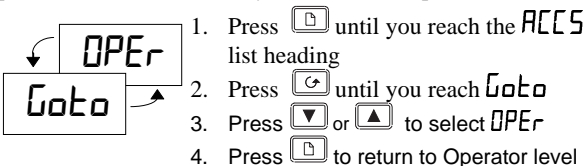

TO USE THE TIMER

- Press until you reach the **SP** list
- Press until you reach the **tm.OP** parameter
- Press or to select the timer operating mode, **OPt. 1** to **OPt. 5** as follows:

OPt. 1 - Mode 1, Dwell and Switch Off

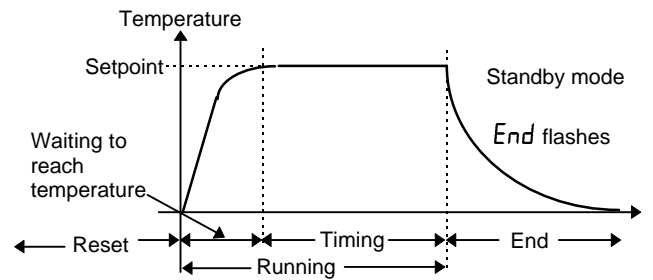

In reset

In reset, you can switch between automatic control and standby mode, using the parameter **m-A** in the HOME list. The controller is supplied with the **m-A** parameter hidden. You must first reveal it. See 'To Hide, Reveal and Promote Parameters'.

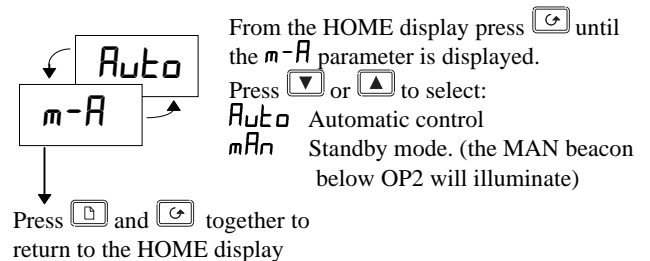

'Automatic control' means control at setpoint, with heating (and cooling) being applied.

'Standby mode' means: the controller is in manual with zero output power. See 'Warning!' on Page 3.

During Running

The controller will always switch to automatic control. Heating (or cooling) will be applied and the temperature will rise (or cool) to the setpoint. When the temperature is within 1°C of setpoint, the timer will start counting down.

During End

When the timer times out, the controller will switch to standby mode. The MAN beacon will light and **End** will be flashed in the main display. The process will cool down. The timer will remain indefinitely in this state until reset.

When Reset

End will stop flashing. The controller will return to reset in standby mode. It can be returned to automatic control by setting the parameter **m-A** in the HOME list to **Auto**.

OPt. 2 - Mode 2, Dwell No Switch Off

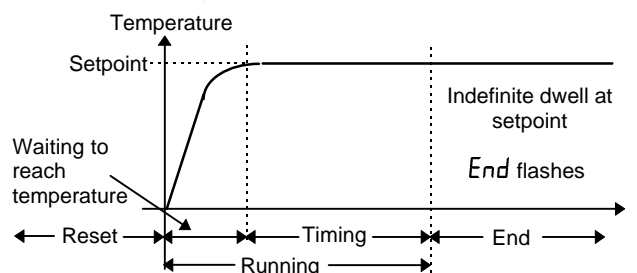

This is the same as mode 1 except that at the end of the timing period the controller will continue indefinitely in automatic



OPER.3 - Mode 3, Time from Cold and Switch Off

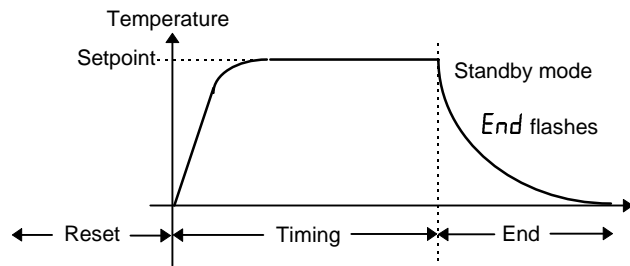

This is the same as mode 1 except that the timer will start counting down immediately without waiting for the temperature to reach setpoint.

OPER.4 Mode 4, Time from Cold No Switch Off

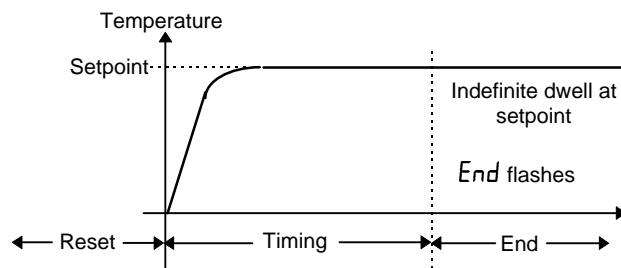

This is the same as mode 2 except that the timer will start counting down without waiting for the controller to reach setpoint.

OPER.5 Mode 5, Delayed Switch On

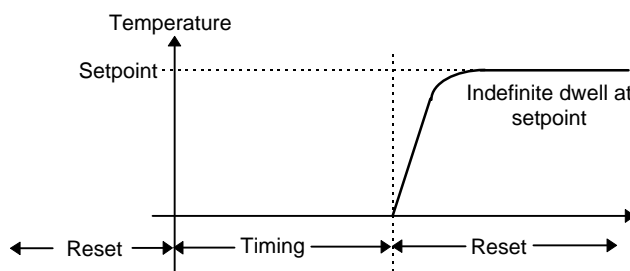

This mode applies a time delay before turning on the heating (or cooling). When the timer is started, the controller will always switch to standby mode and start counting down. When the timer has timed out, the controller will switch into automatic control, apply heating (or cooling) and control indefinitely at the setpoint.

To Program a Ramp-Dwell profile

A simple ramp-dwell profile can be programmed using *SPrr* (setpoint rate limit) in combination with the timer. To use this feature, first reveal *SPrr* and *wSP* (the working setpoint) using the method described in "To Hide, Reveal and Promote" parameters. *wSP* will then appear in the HOME list.

Set *SPrr* to the required ramp rate. It is adjustable in 1/10th of the least significant display units per minute. That is if the display is configured 0 to 1000°C, setpoint rate limit can be adjusted between 0.1 and 999.9 °C per minute.

When setpoint rate limit has been enabled and the timer is started, the working setpoint, *wSP*, will first step to the measured temperature and then ramp at the setpoint rate limit, *SPrr*, to the target setpoint.

In modes 1 and 2 timing will start when the measured temperature is within 1°C of the target setpoint. In modes 3 and 4 it will start when *wSP* is within 1°C of the target setpoint.

TO START AND RESET THE TIMER

There are two methods:

Method 1.

This is the simplest method to control the timer.

- Press until you reach the *SP* list
- Press until you reach the *tmr* parameter (time remaining).

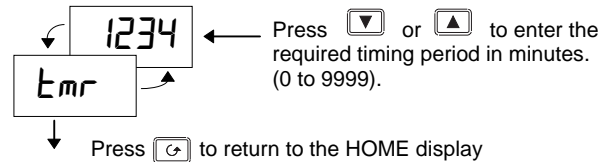

TIP: Promote *tmr* to the HOME list for quick access, as described in 'To Hide, Revealing and Promote Parameters'.

As soon as a value is entered into *tmr* timing will commence. *tmr* will count down towards zero. During the timing period *tmr* can be increased or decreased according to the demands of the process. Setting the value to zero will end the timing period.

When *tmr* reaches zero, 'End' will flash in the main display. The timer will remain indefinitely in this state until a new value is entered, when the timer will restart.

To reset the timer, press and together. 'End' will stop flashing.

To restart the timer, enter a new value into *tmr*.

Method 2.

Use this method if you want to set a fixed time and use the *STAT* parameter to start and stop the timer.

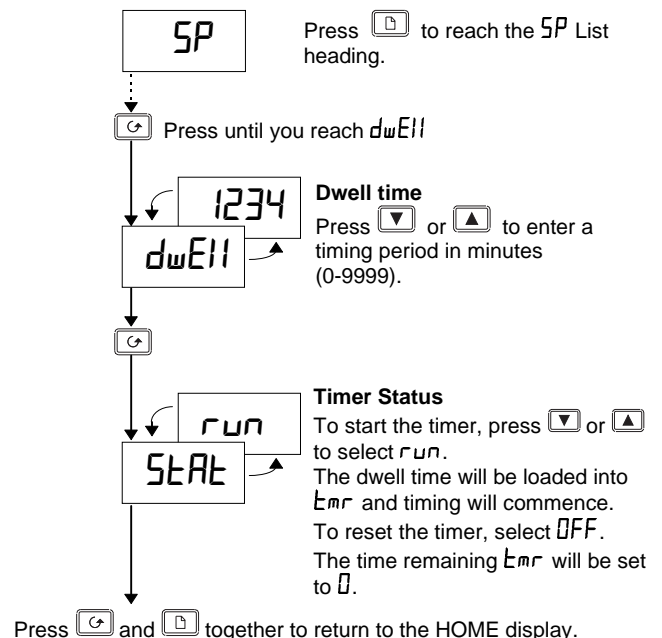

The *STAT* parameter can also be switched between *OFF* and *run* by configuring the logic I/O as a Off/run contact closure input.

Open the external contact to select *run*. This is an edge triggered action. Close the contact to select *OFF*. *OFF* is forced whenever the contact is closed.

CONFIGURING THE CONTROLLER

Select configuration level to change: •The type of control •The display units •The input sensor type• The scaling of linear inputs •The alarm configuration • The passwords.

To select configuration level

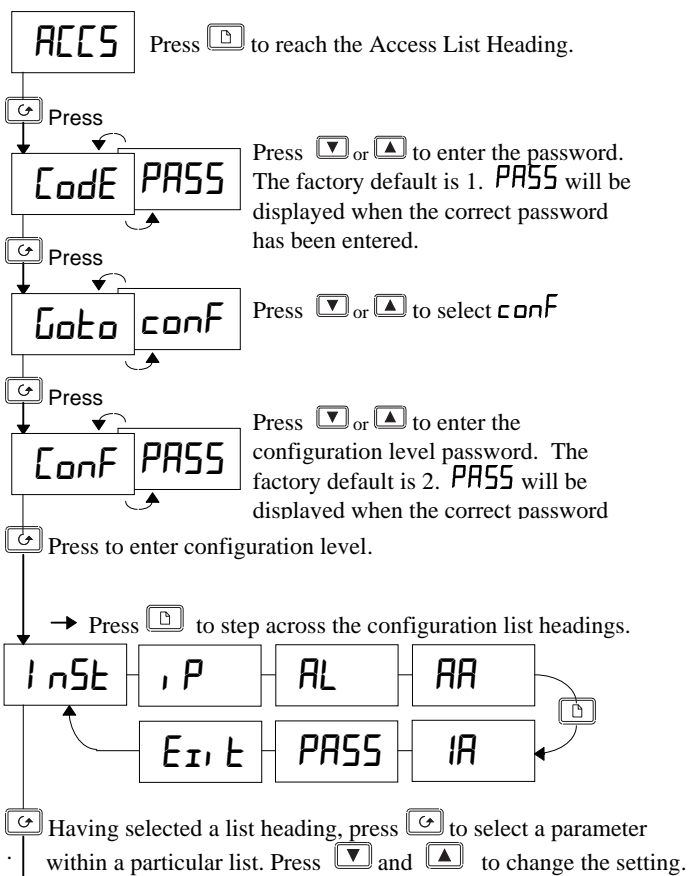

Instrument Configuration

Inst	Instrument Configuration	Options	Description
uni t	Display <u>units</u>	°C °F °K none	Centigrade Fahrenheit Kelvin None
dE.C.P	<u>Decimal places</u> in display	none One Two	None One Two
Ctrl	<u>Control type</u>	P, I, D On/Off AL	PID Control On/off Control Converts the controller to an <u>alarm</u> unit
Act	<u>Control action</u>	rE, u d, i, r	<u>Reverse</u> (normal action for temperature control) <u>Direct</u> (output decreases as PV falls below SP)
Pd, tr	Manual reset <u>tracking</u> (PD control)	HoLd trAc	In Auto <u>holds</u> manual reset value In Auto <u>tracks</u> output for bumpless A/M transfer

Input Configuration

IP	Sensor Input	Options	Meaning
IPt	<u>Input type</u>	J.t.c K.t.c L.t.c R.t.c B.t.c N.t.c I.t.c S.t.c PL 2 r.t.d mV C.t.c	J thermocouple K thermocouple L thermocouple R thermocouple B thermocouple N thermocouple I thermocouple S thermocouple Platinell II 100Ω Pt thermometer Linear mV Custom input(C=default)
CJC	<u>Cold junction compensation</u> (only appears for TC inputs)	Auto 0°C 45°C 50°C	Automatic 0°C external reference 45°C external reference 50°C external reference
Linear input scaling (Range -12 to +80mV)			
IP.L	mV <u>input low</u>		
IP.H	mV <u>input high</u>		
UAL.L	Displayed <u>value low</u>		
UAL.H	Displayed <u>value high</u>		
IP	Sensor break input <u>impedance</u>	OFF Auto H H, H	Off (Linear inputs only) 1.5KΩ 5KΩ 15KΩ

Alarm Configuration

The **AL** list configures the three internal 'soft' alarms and causes the appropriate alarm message to be flashed in the HOME display.

At this stage the alarm is indication only (known as a 'soft alarm'). To make the alarms operate the relay or logic outputs, follow the instructions under "Relay and Logic input/output Configuration.

AL	Alarm	Type	Meaning
AL 1	<u>Alarm 1</u>	OFF FSL FSH dE, u dH, i dL, o	The alarm is disabled Full Scale Low alarm Full Scale High alarm Deviation band alarm Deviation high alarm Deviation low alarm
ALch	<u>Alarm latching</u>	no YES mAn	Non-latching Latched with automatic* resetting. Latched with <u>manual</u> * resetting.
ALoc	<u>Alarm blocking</u>	no YES	No blocking Blocked until first good
The above sequence is repeated for: AL 2 (Alarm 2) and AL 3 (Alarm 3)			
SP.L	Alarm setpoint limits	d, 5 Con	Limited by display range Limited by setpoint limits

*Automatic resetting means that, once the alarm has been acknowledged, it will automatically clear when it is no longer true.
*Manual resetting means that the alarm must first clear before it can be reset.



Relay and Logic input/output Configuration

Note: The logic I/O can be configured as an output or a contact closure input for alarm acknowledge, keylock, or timer run/reset.

AA	Relay output	Options	Meaning
IA	Logic I/O		
id	Identity of output	REL LOG	Relay Logic
Func	Function	dG	Digital (alarm) output
		HEAT	Heating output
Func	Function	COOL	Cooling output
		SSr.1	PDSIO mode 1
Func	Function	Ac.AL	Alarm Acknowledge
		Loc.b	Keylock digital input
Func	Function	rrES	Run/reset timer
dGF	Digital output functions	nach	No change
		CLr	Clear all alarms
		1FSL	Alarm 1 (See note 1)
		2FSL	Alarm 2 (See note 1)
		3FSL	Alarm 3 (See note 1)
		nw *	New alarm
		Sbr *	Sensor break alarm
		Lbr *	Loop break alarm
		LdF *	Load fail alarm
		mAn *	Man mode active
		End *	End of timing
		tmg.1 *	Timer running
tmg.2 *	Timer counting down		
(See note 2)	tmg.3 *	Timer running	
(See note 2)	tmg.4 *	Timer counting down	
Sen5	Sense of the output	nor	Normal (heating or cooling outputs)
		inu	Inverted (for alarms de-energises in alarm)

* These alarms are always non-latching. Process alarms 1, 2 and 3 are configurable as alarm latching or non-latching, see the 'AL' List

Note 1: The last three letters will correspond to the alarm type configured in the AL list. If the alarm is disabled, AL 1 or AL 2 or AL 3 will be shown.

Note 2: tmg.3 and tmg.4 are special functions. If selected, they illuminate the logic or relay output beacons, OP1 and OP2, without operating the actual output. They are used to indicate that timing is in progress while leaving the actual outputs to be operated by the other digital functions such as the END condition which can be used to operate an external klaxen.

To Operate the Relay or Logic output from an alarm or digital function.

- Press until you reach Func
- Press or to select Func = dG
- Press to reach dGF
- Press or to select a alarm or digital function
- Leave for 2 seconds. The display returns to dGF and connects the selected alarm or digital function to the relay or logic output.
- Press or again. Two decimal points will appear in the function that has been added to the output.

Multiple Alarms on one Output

Any number of alarms or digital functions can be added to the relay or logic output by repeating steps 4, 5 and 6 above. Two decimal points will appear in those functions that has been added to the output.

.....Continued in the next column

To Clear Alarms from an Output

- Press until to reach dGF
- Press or to select CLr
- Leave for 2 seconds. The display returns to dGF which disconnects all alarms from the relay.

Passwords

PASS	Passwords	Range	Default
ALCP	Full and Edit level password	0-9999	1
CLFP	Configuration level password	0-9999	2
CALP	User calibration password	0-9999	3

To leave Configuration level

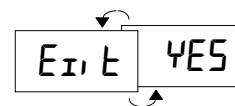

Press to reach the 'E1t' display
Press or to select 'YES' After 2 secs the display will blink and return to the HOME display in Operator level.

Diagnostic Alarms

In addition to the normal process alarms, the following diagnostics alarm messages are provided.

Message	Meaning and (Action)
EEEr	Electrically Erasable Memory Error: A parameter value has been corrupted. Contact Eurotherm Controls.
HwEr	Hardware error. (Return for repair)
LLLL	Low display range exceeded: (Check input signal)
HHHH	High display range exceeded: (Check input signal)
Err1	Error 1: ROM self-test fail. (Return for repair)
Err2	Error 2: RAM self-test fail. (Return for repair)
Err3	Error 3: Watchdog fail. (Return for repair)
Err4	Error 4: Keyboard failure. Stuck button, or a button was pressed during power up.
Err5	Error 5: Input circuit failure. (Return for repair)
Pwr.F	Power failure. The line voltage is too low.
tUEr	Tune Error. Appears if auto-tuning exceeds 2 hours.

USER CALIBRATION

Your controller has been calibrated for life against known reference sources. User calibration allows you to apply offsets to compensate for sensor and other system errors. The parameter DFS in the P list applies a fixed offset over the whole display range. You may also apply a 2-point calibration as follows:

- Press until you reach the P list
- Press until you reach the CALP parameter
- Press or to enter the password. The factory default is 3. PASS will be displayed when the correct has been entered.
- Press to reach the CAL parameter
- Press or , to select USER (FACT will restore the factory calibration)
- Press to select in turn the four parameters shown in the graph below. Use or to set the desired calibration points and the offsets to be applied at each point. The P list on page 5 describes each of the parameters.

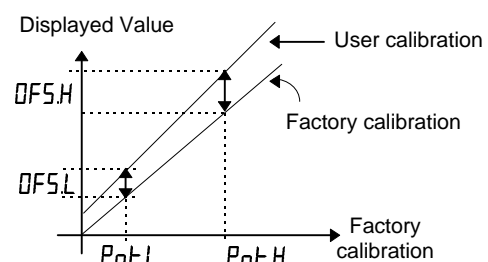

AUTOMATIC TUNING

In PID control, the output from the controller is the sum of three terms: **Proportional**, **Integral** and **Derivative**. These three terms deliver just the right amount of power to hold the temperature at setpoint without oscillation. For stable control, the PID values must be 'tuned' to the characteristics of the process being controlled. In the 2132 and 2116 this is done automatically using advanced tuning techniques.

Automatic tuning is performed by switching the output of the controller On and Off to induce an oscillation in the measured temperature. From the amplitude and period of the oscillation, the PID values, shown in the table below, are calculated.

Parameter	Display	Meaning or Function
Proportional band	Pb	The bandwidth in °C or °F over which the output power is proportioned between minimum and maximum.
Integral time	ti	Determines the time taken by the controller to remove steady-state error signals.
Derivative time	td	Determines how strongly the controller will react to the rate-of-change of temperature.
Low cutback	Lcb	The number of °C or °F below setpoint at which the controller will cutback the output power to prevent overshoot on heat up.
High Cutback	Hcb	The number of °C or °F above setpoint at which the controller will increase the output power to prevent undershoot on cool down.
Relative cool gain	rELC	Only present if cooling has been configured. Sets the cooling proportional band by dividing the Pb value by the rELC value.

If the process cannot tolerate 100% heating or cooling during tuning, the power can be restricted by the heating and cooling limits in the Output list. However, the measured value *must* oscillate to some degree for the tuner to determine values. Tuning is normally performed only once during the initial commissioning of the process. However, if the process under control subsequently becomes unstable (because its characteristics have changed), you can re-tune again at any time. It is best to tune starting with the process at ambient temperature. This allows the tuner to calculate more accurately.

Heating and Cooling Output Cycle Times

Before commencing a tuning cycle, set the values of CYCH (heating output cycle time) and CYCL (cooling output cycle time) in the OP (output) list.

For a logic heating output (switching a SSR), set CYCH to 1.0 sec. For a relay output, set CYCH to 20.0 sec.

For a logic cooling output used to control a solenoid valve, set CYCL to 5.0 sec.

Tuning procedure

1. Set the setpoint to the value at which you will normally operate the process.
2. In the 'Atun' list, select 'tunE' and set it to 'on'
3. Press the Page and Scroll buttons together to return to the HOME display. The display will flash 'tunE' to indicate that tuning is in progress.
4. The controller will induce an oscillation in the temperature by turning the heating on and then off.
5. After two cycles of oscillation the tuning will be completed and the tuner will switch itself off.
6. The controller will then calculate the tuning parameters and resume normal control action.

If you want 'Proportional only' or 'P+D' or 'P+I' control, you should set the 'ti' or 'td' parameters to OFF before commencing the tuning cycle. The tuner will leave them off and will not calculate a value for them.

Typical automatic tuning cycle

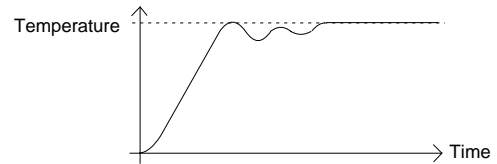

Calculation of the cutback values

When low cutback or high cutback is set to 'Auto' their values will be fixed at three times the proportional band, and will not be altered during automatic tuning. If set to any other value, they will be calculated as part of the tuning process.

MANUAL TUNING

If for any reason automatic tuning gives unsatisfactory results, you can manually tune the controller.

Proceed as follows:

With the process at its normal running temperature:

1. Set the *Integral Time* 'ti' and *Derivative Time* 'td' to OFF.
2. Set *High Cutback* 'Hcb' and *Low Cutback* 'Lcb', to 'Auto'.
3. Ignore the fact that the temperature may not settle precisely at the setpoint
4. Reduce the *proportional band* 'Pb' until the temperature just starts to oscillate. If the temperature is already oscillating, increase the proportional band until it just stops oscillating. Allow enough time between each adjustment for the temperature to stabilise. Make a note of the proportional band value 'B' and the period of oscillation 'T'.
5. Set the PID parameter values according to the formula below:

Type of control	Proportional band 'Pb'	Integral time 'ti'	Derivative time 'td'
Proportional only	2xB	OFF	OFF
P + I	2.2xB	0.8xT	OFF
P + I + D	1.7xB	0.5xT	0.12xT

Setting the cutback values

The above procedure sets up the parameters for optimum steady state control. If unacceptable levels of overshoot or undershoot occur during start-up or for large step changes in temperature, then manually set the cutback parameters Lcb and Hcb.

Proceed as follows:

1. Set the low and high cutback settings to 3 x the proportional band (that is to say, Lcb = Hcb = 3 x Pb).
 2. Note the level of overshoot or undershoot that occurs for large temperature changes (see the diagrams below).
- In example (a) increase Lcb by the overshoot value. In example (b) reduce Lcb by the undershoot value.

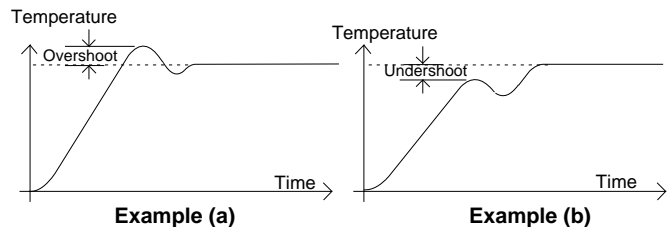

When the temperature approaches the setpoint from above, you can set Hcb in a similar manner.

Manual reset

When ti = OFF manual reset (rES) appears in the PID List. This parameter sets the output power when the error signal is zero. It can be manually adjusted to remove steady state error - the function normally performed by the Integral term.



ORDERING CODE

The controller is supplied configured according to the ordering code shown below.

Model number	Function	Supply voltage	Manual	Output 1 (Logic)	Output 2 (Relay)	Sensor input	Setpoint min	Setpoint max	Units	External relay module	Input adaptor
2132 2116											

Function	
CC	PID controller
NF	On/Off controller
TC	PID controller + timer
TN	On/Off controller + timer

Supply voltage	
VH	85-264Vac
VL	20 -29V dc or ac

Manual	
XXX	None
ENG	English
FRA	French
GER	German
NED	Dutch
SPA	Spanish
SWE	Swedish
DEN	Danish
ITA	Italian

Output 1: Logic	
XX	Disabled
Logic output	
LH	Heating
LC	Cooling
M1	PDSIO mode 1
FH	High alarm 1
FL	Low alarm 1
DB	Dev band alarm 1
DL	Dev. low alarm 1
DH	Dev. high alarm 1
NW	New alarm
Logic input	
AC	Alarm ack/reset
KL	Keylock
TM	Timer Run/Reset

Output 2: Relay	
XX	Disabled
RH	Heating
RC	Cooling
FH	High alarm 2
FL	Low alarm 2
AL	High alarm 2 & low alarm 3
DB	Dev band alarm 2
DL	Dev. low alarm 2
DH	Dev. high alarm 2
NW	New alarm

Sensor input		Display range and Setpoint min & max limits	
Thermocouples			
J	Type J	-210 to 1200	-340 to 2192
K	Type K	-200 to 1372	-325 to 2500
T	Type T	-200 to 400	-325 to 750
L	Type L	-200 to 900	-325 to 1650
N	Type N	-200 to 1300	-325 to 2370
R	Type R	-50 to 1768	58 to 3200
S	Type S	-50 to 1768	-58 to 3200
B	Type B	0 to 1820	32 to 3308
P	Platinell II	0 to 1369	32 to 2496
Resistance thermometer			
Z	Pt100	-200 to 850	-325 to 1562
Custom downloaded inputs			
C	Type C -W5%Re/W26%Re (default custom sensor)	0 to 2319	32 to 4200
D	Type D - W3%Re/W25%Re	0 to 2399	32 to 4350
E	E thermocouple	-200 to 999	-325 to 1830
1	Ni/Ni18%Mo	0 to 1399	32 to 2550
2	Pt20%Rh/Pt40%Rh	0 to 1870	32 to 3398
3	W/W26%Re (Engelhard)	0 to 2000	32 to 3632
4	W/W26%Re (Hoskins)	0 to 2010	32 to 3650
5	W5%Re/W26%Re (Engelhard)	10 to 2300	50 to 4172
6	W5%Re/W26%Re(Bucose)	0 to 2000	32 to 3632
7	Pt10%Rh/Pt40%Rh	200 to 1800	392 to 3272
8	Exegen K80 I.R. Pyrometer	-45 to 650	-49 to 1202
Process inputs (linear)			
M	-9.99 to +80mV	Scaleable	-999 to 9999
Y	0 to 20mA	Scaleable	-999 to 9999
A	4 to 20mA	Scaleable	-999 to 9999
V	0 to 10Vdc (input adaptor required)	Scaleable	-999 to 9999

Units	
C	°C
F	°F
K	Kelvin
X	Linear input

External relay module	
XX	Not fitted
R7	Fitted (Operated by the logic output)

Input Adaptor	
XX	None
V1	0-10Vdc
A1	0-20mA sense resistor (2.49Ω. 0.1%)

TECHNICAL SPECIFICATION

Panel sealing	IP65 (EN 60529), or 4X (NEMA 250)
Operating ambients	0 to 55°C. Ensure that the enclosure is adequately ventilated. 5 to 95%RH, non condensing
Storage temperature	-30°C to +75°C. (Protect from humidity and dust)
Atmosphere	Not suitable for use above 2000m or in explosive or corrosive atmospheres
Power supply	High voltage unit: 100 to 240Vac -15%, +10%, 48-62Hz, 5Watts maximum consumption Low voltage unit: 24Vdc/ac +/- 20%. DC to 62Hz, 5Watts maximum consumption
Relay rating (isolated)	Maximum: 264Vac, 2A resistive. Minimum: 12Vdc, 100mA Mechanical life > 10 ⁷ operations. Electrical life at 1A, 240vac resistive load > 5 x 10 ⁶ operations
Wire sizes	Use a minimum of 0.5mm ² or 16awg wire for plant connections.
Over current protection	Use independent 2A fuses for the indicator supply and relay output. Suitable fuses are EN60127 (type T)
Logic output/input rating	9V at 12mA, non-isolated from sensor input
Electrical safety	Meets EN 61010 (Voltage transients on the power supply must not exceed 2.5kV). Pollution degree 2.
Isolation:	All isolated inputs and outputs have reinforced insulation to protect against electric shock. (See live sensor note)
Cold Junction Compensation	>30 to 1 rejection of ambient temperature changes in automatic mode. Uses INSTANT ACCURACY™ cold junction sensing technology to eliminate warm up drift and to respond quickly to ambient temperature changes.

SAFETY AND EMC INFORMATION

Safety

This controller complies with the European Low Voltage Directive 73/23/EEC, amended by 93/68/EEC, by the application of the safety standard EN 61010.

Electromagnetic compatibility

It conforms with the essential protection requirements of the EMC Directive 89/336/EEC, amended by 93/68/EEC, by the application of a Technical Construction File. It satisfies the general requirements of the industrial environment defined in EN 50081-2 and EN 50082-2.

GENERAL

The information contained in these instructions is subject to change without notice. While every effort has been made to ensure the accuracy of the information, Eurotherm Controls shall not be held liable for errors contained herein.

Unpacking and storage

The packaging should contain the controller with two panel retaining clips and this instruction leaflet.

If the packaging or the controller are damaged, do not install the product but contact your nearest Eurotherm Controls agent.



Tel: (01943) 602001- WWW.ISSLTD.CO.UK - Fax: (01943) 816796



SERVICE AND REPAIR

This controller has no user serviceable parts. Contact your nearest Eurotherm Controls agent for repair.

Caution: Charged capacitors

Before removing the controller from its sleeve, switch off the supply and wait two minutes to allow capacitors to discharge. Failure to observe this precaution may damage the indicator or cause some discomfort to the user.

Electrostatic discharge precautions

When the controller is removed from its sleeve, it is vulnerable to damage by electrostatic discharge from someone handling the controller. To avoid this, before handling the unplugged controller discharge yourself to ground.

Cleaning

Do not use water or water based products to clean labels or they will become illegible. Isopropyl alcohol may be used to clean labels. A mild soap solution may be used to clean other exterior surfaces of the product.

Safety Symbols

The following safety symbols are used on the controller:



Caution. Refer to the accompanying documents

Personnel

Installation must be carried out by qualified personnel.

Enclosure of live parts

The controller must be installed in an enclosure to prevent hands or metal tools touching parts that may be electrically live.

Caution: Live sensors

The logic input/output is electrically connected to the sensor input (e.g. thermocouple). In some installations the temperature sensor may become live. The controller is designed to operate under these conditions, but you must ensure that this will not damage other equipment connected to the logic input/output and that service personnel do not touch this connection while it is live. With a live sensor, all cables, connectors and switches for connecting the sensor and non-isolated inputs and outputs must be mains rated.

Wiring

Wire the controller in accordance with the wiring data given in these instructions. Take particular care not to connect AC supplies to the low voltage sensor input or logic outputs. Only use copper conductors for connections, (except thermocouple). Ensure that the installation complies with local wiring regulations. In the USA use NEC Class 1 wiring methods.

INTERNATIONAL SALES AND SERVICE

Power Isolation

Include a power isolating switch or circuit breaker which disconnects all current carrying conductors. The device should be mounted in close proximity to the controller, within easy reach of the operator and marked as the disconnecting device for the controller.

Voltage rating

The maximum continuous voltage applied between any connection and ground must not exceed 264Vac. For the above reason the controller should not be wired to a three phase supply with a non-grounded star connection. Under fault conditions such a supply could rise above 264Vac with respect to ground and the product would not be safe.

Over-temperature protection

When designing any control system it is essential to consider what will happen if any part of the system should fail. In temperature control applications the primary danger is that the heating will remain constantly on. This could damage the product, the machinery being controlled, or even cause a fire.

Reasons why the heating might remain constantly on include:

- the temperature sensor becoming detached from the process
- thermocouple wiring becoming short circuit;
- the controller failing with its heating output constantly on
- an external valve or contactor sticking in the heating condition

Where damage or injury is possible, we recommend fitting a separate over-temperature protection unit, with an independent temperature sensor, which will isolate the heating circuit.

Please note that the alarm relays within the controller will not give protection under all failure conditions.

Conductive pollution

Electrically conductive pollution must be excluded from the cabinet in which the indicator is mounted. For example, carbon dust is a form of electrically conductive pollution. Where condensation is likely, for example at low temperatures, include a thermostatically controlled heater in the cabinet.

Installation requirements for EMC

- For general guidance refer to Eurotherm Controls EMC Installation Guide, HA025464.
- It may be necessary to fit a filter across the relay output to suppress conducted emissions. The filter requirements will depend on the type of load. For typical applications we recommend Schaffner FN321 or FN612.

Routing of wires

To minimise the pick-up of electrical noise, the sensor input wiring should be routed away from high-current power cables. Where it is impractical to do this, use shielded cables with the shield grounded at both ends.

Distributed by



PO Box 1 • Ilkley • West Yorkshire • LS29 8EU

Phone: 01943 602001 • Fax: 01943 816796

Website: www.issltd.co.uk • Email: sales@issltd.co.uk

Instrumentation
Systems & Services Ltd

Tel: (01943) 602001- WWW.ISSLTD.CO.UK - Fax: (01943) 816796

