



PO Box 1 • Ilkley • West Yorkshire • LS29 8EU
Phone: 01943 602001 • Fax: 01943 816796
Website: www.issltd.co.uk • Email: sales@issltd.co.uk

instrumentation
Systems & Services Ltd





ABB





Electrical Safety

This equipment complies with the requirements of CEI/IEC 61010-1:2001-2 "Safety Requirements for Electrical Equipment for Measurement, Control and Laboratory Use". If the equipment is used in a manner NOT specified by the Company, the protection provided by the equipment may be impaired.

Symbols

One or more of the following symbols may appear on the equipment labelling:

	Warning – Refer to the manual for instructions
	Caution – Risk of electric shock
	Protective earth (ground) terminal
	Earth (ground) terminal

	Direct current supply only
	Alternating current supply only
	Both direct and alternating current supply
	The equipment is protected through double insulation

Information in this manual is intended only to assist our customers in the efficient operation of our equipment. Use of this manual for any other purpose is specifically prohibited and its contents are not to be reproduced in full or part without prior approval of the Technical Publications Department.

Health and Safety

To ensure that our products are safe and without risk to health, the following points must be noted:

1. The relevant sections of these instructions must be read carefully before proceeding.
2. Warning labels on containers and packages must be observed.
3. Installation, operation, maintenance and servicing must only be carried out by suitably trained personnel and in accordance with the information given.
4. Normal safety precautions must be taken to avoid the possibility of an accident occurring when operating in conditions of high pressure and/or temperature.
5. Chemicals must be stored away from heat, protected from temperature extremes and powders kept dry. Normal safe handling procedures must be used.
6. When disposing of chemicals ensure that no two chemicals are mixed.

Safety advice concerning the use of the equipment described in this manual or any relevant hazard data sheets (where applicable) may be obtained from the Company address on the back cover, together with servicing and spares information.

GETTING STARTED

This manual is divided into 5 sections which contain all the information needed to install, configure, commission and operate the COMMANDER 100. Each section is identified clearly by a symbol as shown below.



Displays and Function Keys

- Displays and function keys
- LED Indication
- Error Messages



Operator Mode (Level 1)

- Operator menus for:
 - *Standard controller*
 - *Heat/Cool controller*
 - *Remote Set Point controller*
 - *Profile controller*
 - *Multiple Fixed Set Points controller*
- Auto tuning



Set Up Mode (Levels 2, 3 and 4)

- Level 2 – Tuning
- Level 3 – Set Points
- Level 4 – Profile



Configuration Mode (Levels 5 and 6)

- Level 5 – Basic hardware and control functions
- Level 6 – Ranges and passwords



Installation

- Siting
- Mounting
- Electrical connections

Symbol Identification and Section Contents

CONTENTS

1	DISPLAYS AND FUNCTION KEYS	3
1.1	Introduction	3
1.2	Use of Function Keys	4
1.3	LED Alarms and Indicators	5
1.4	Error Messages	6
2	OPERATOR MODE	7
2.1	Introduction	7
2.2	Standard Controller	8
2.3	Heat/Cool Controller	9
2.4	Remote Set Point Controller	10
2.5	Profile Controller	12
2.6	Multiple Fixed Set Points Controller	14
2.7	Auto-tune	16
3	SET UP MODE	18
3.1	Introduction	18
3.2	Tuning (Level 2)	18
3.3	Set Points (Level 3)	22
3.4	Profile (Level 4)	25
4	CONFIGURATION MODE	28
4.1	Introduction	28
4.2	Accessing the Configuration Mode	28
4.3	Basic Hardware and Configuration (Level 5)	30
4.4	Ranges and Passwords (Level 6)	40
5	INSTALLATION	43
5.1	Siting	44
5.2	Mounting	46
5.3	Electrical Connections	48
5.4	Relays, Arc Suppression and Outputs	50
	SPECIFICATION	51

Note.

The fold-out page inside on the back cover of this manual shows all the frames in the programming levels. Space is provided on the page for writing the programmed setting or selection for each frame.

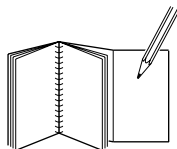

1 DISPLAYS AND FUNCTION KEYS

1.1 Introduction – Fig. 1.1

The COMMANDER 100 front panel displays, function keys and LED indicators are shown in Fig. 1.1.

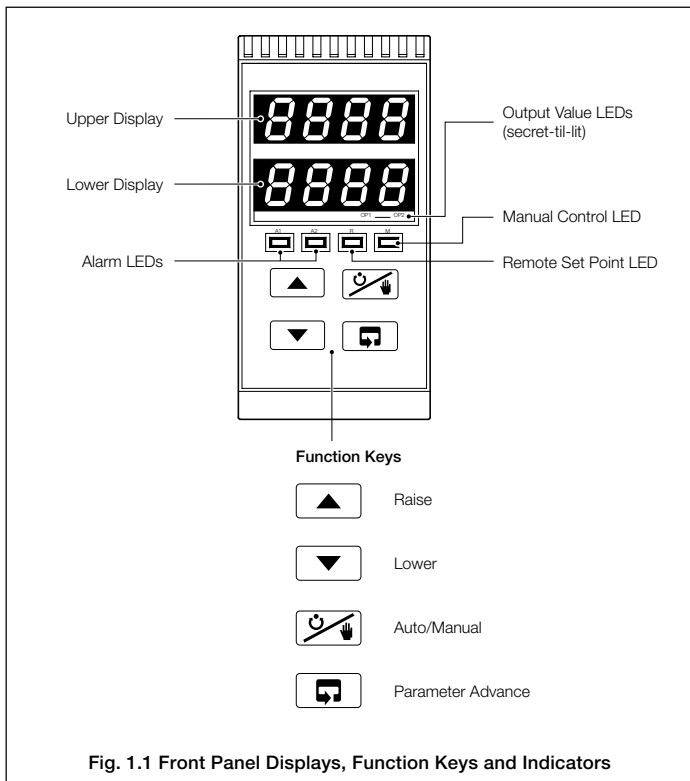

1.2 Use of Function Keys

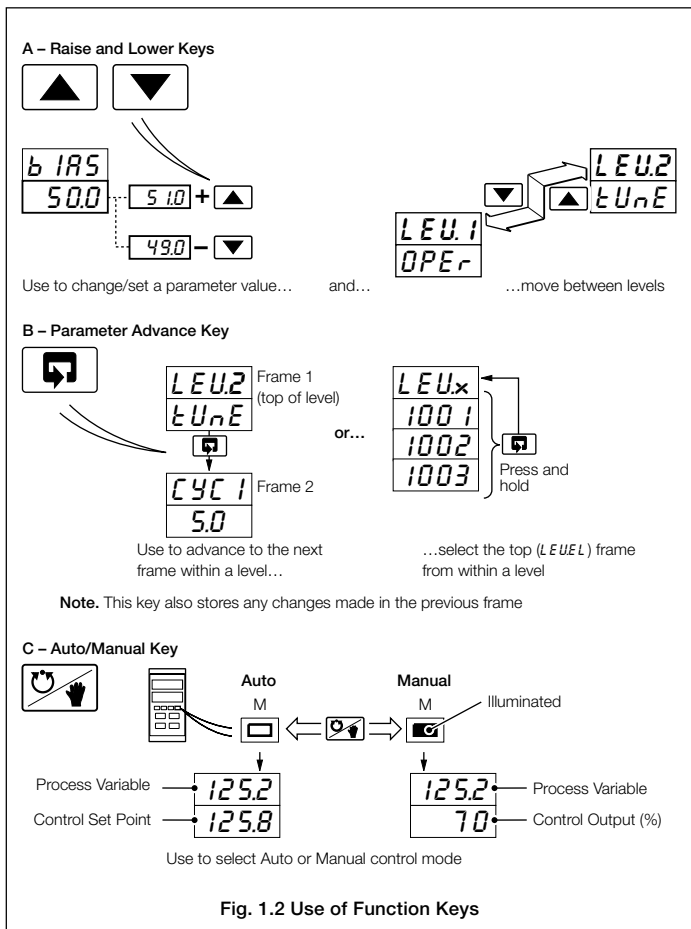
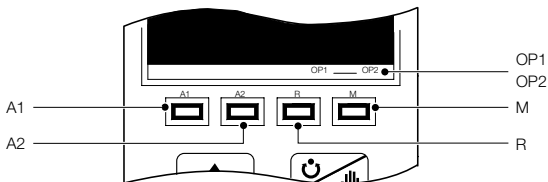

Fig. 1.2 Use of Function Keys

1.3 LED Alarms and Indicators

**LED Status**

- All**
 - All LED's flashing – controller is in the configuration mode.
- A1**
 - Flashes when Alarm 1 is active (off when inactive).
- A2**
 - Flashes when Alarm 2 is active (off when inactive).
- R**
 - On when the controller is operating on the remote set point value.
 - Off when the controller is operating using the local set point value or one of the four fixed set points (in multiple set point mode).
 - Flashes when a Ramp/Soak profile is running.
- M**
 - On when the controller is operating in Manual control mode.
 - Off when the controller is operating in Auto control mode.
 - Flashes when the controller is performing an auto-tune.
- OPI**
 - Secret-til-lit LED indicates when the output 1 (heat) value is displayed in the lower display.
- OP2**
 - Secret-til-lit LED indicates when the output 2 (cool) value is displayed in the lower display.

Fig. 1.3 LED Alarms and Indicators

1.4 Error Messages

Display	Error/Action	To Clear Display
	Calibration Error Turn mains power off and on again. (If the error persists contact the Service Organization).	Press the key
	Calibration Error The configuration and/or setup data for the instrument is corrupted. Turn mains power off and on again (if the error persists, check the configuration/setup settings).	Press the key
	A to D Converter Fault The analog to digital converter is not communicating correctly.	Turn mains power off & on again. if the error persists contact the Service Organization
	Process Variable Over/Under Range	Restore valid input
	Remote Set Point Over/Under Range The remote set point value is over or under range. Flashing stops automatically when the remote set point comes back into range.	Select the local set point (<i>r SP.n</i>) in the Operating Page or the Set Points Level
	Option Error Communications to the option board have failed.	Contact the Service Organization
	Auto-tune Error The number displayed indicates the type of error present – see Table 2.1 in Section 2.7.	Press any key.



2 OPERATOR MODE

2.1 Introduction

Operator Mode (Level 1) is the normal day-to-day mode of the COMMANDER 100.

Frames displayed in level 1 are determined by the control strategy which is selected during configuration of the instrument – see Section 4.

Note. Only the operating frames relevant to the configured strategy are displayed in Operator Mode.

The five control strategies are:

- **Standard controller** – page 8
- **Heat/Cool controller** – page 9
- **Remote Set Point controller** – page 10
- **Profile controller** – page 12
- **Multiple Fixed Set Points controller** – page 14



2.2 Standard Controller

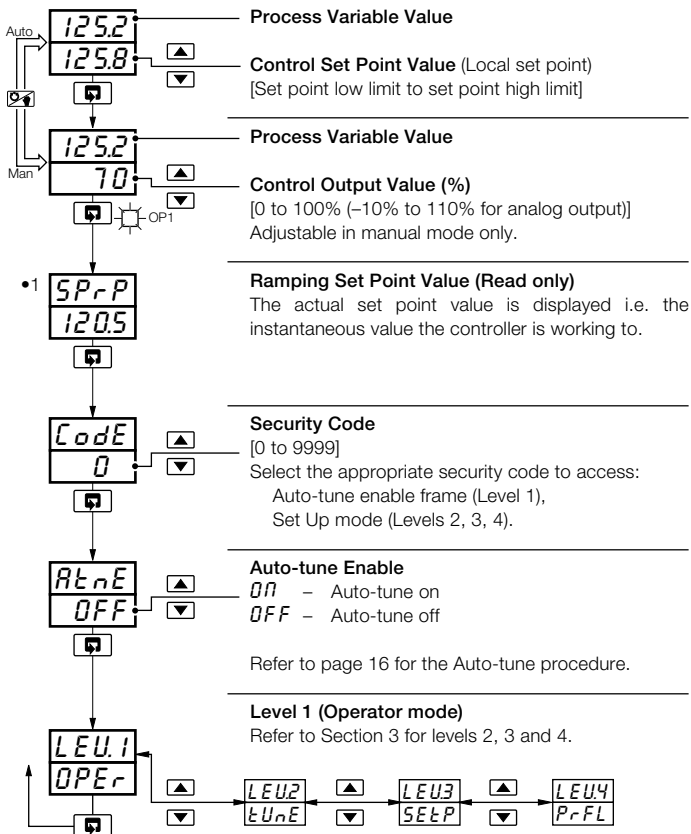

•1 Not displayed if the ramping set point facility is turned off – refer to Section 3.3.



2.3 Heat/Cool Controller

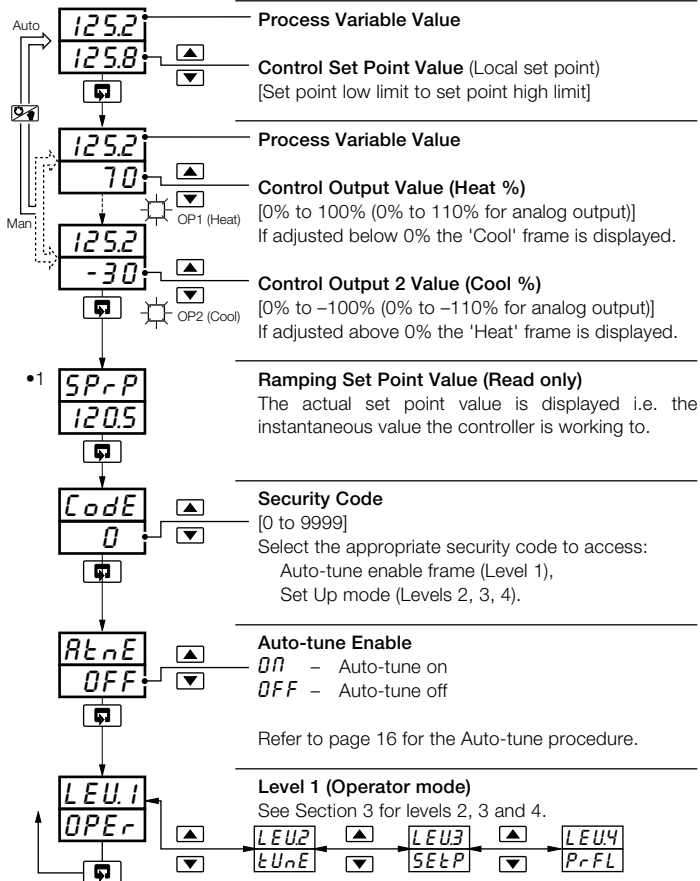

•1 Not displayed if the ramping set point facility is turned off – refer to Section 3.3.



2.4 Remote Set Point Controller

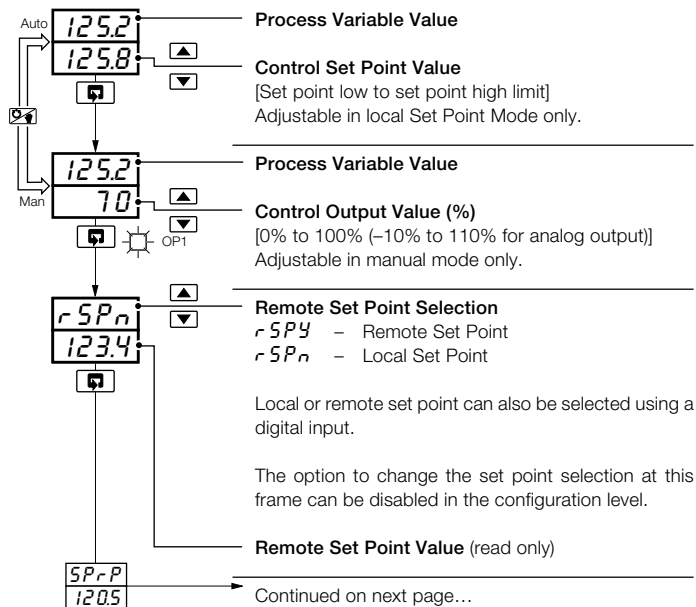

Note. If the remote set point input fails while selected, the controller automatically selects the local set point value. The upper display changes to rSP_F and the lower display flashes. When the fault condition is removed the remote set point is re-selected automatically. To clear the error condition while the remote set point input is still outside its allowed range, select the local set point by pressing the ∇ key (rSP_n is displayed).



...2.4 Remote Set Point Controller

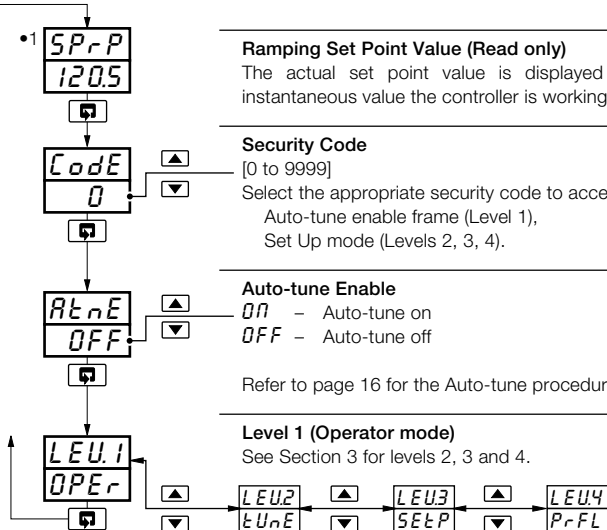

- 1 Not displayed if the ramping set point facility is turned off – refer to Section 3.3.



2.5 Profile Controller

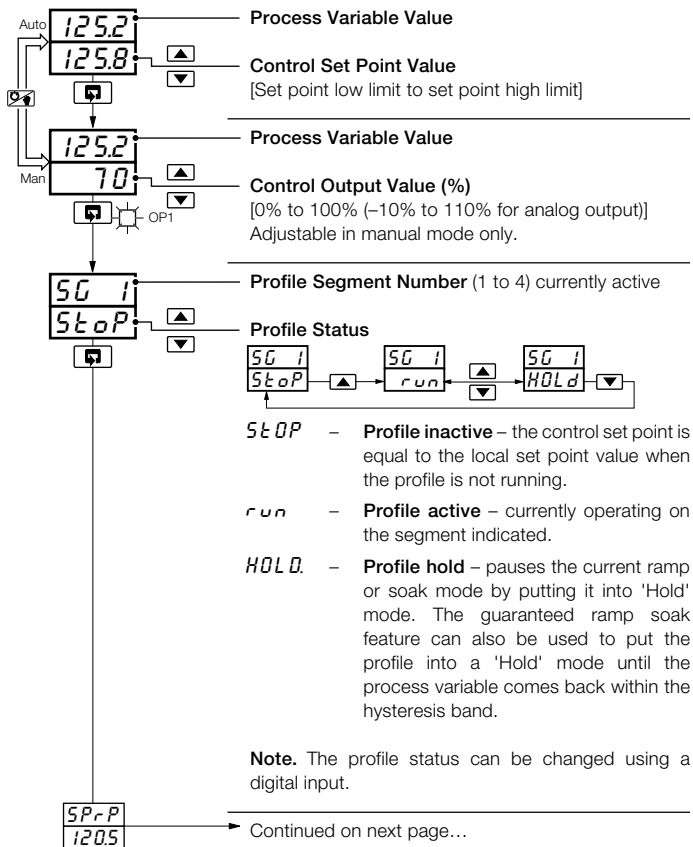



...2.5 Profile Controller

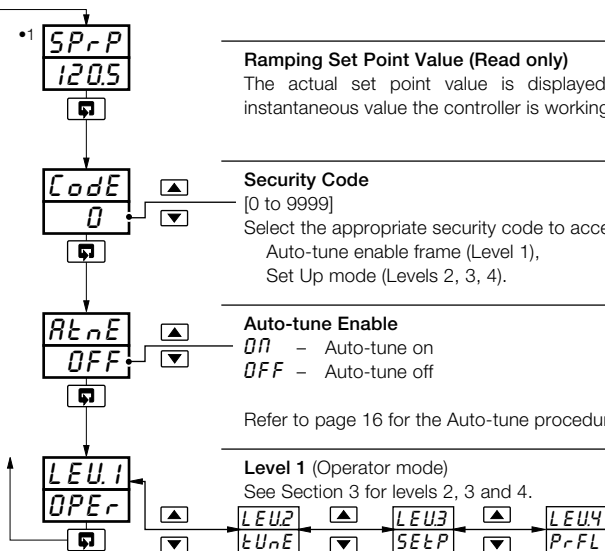

- 1 Not displayed if the ramping set point facility is turned off – refer to Section 3.3.



2.6 Multiple Fixed Set Points Controller

If the Multiple Fixed Set Points Controller type is selected during configuration, four fixed control set points can be set – see Section 4.4.

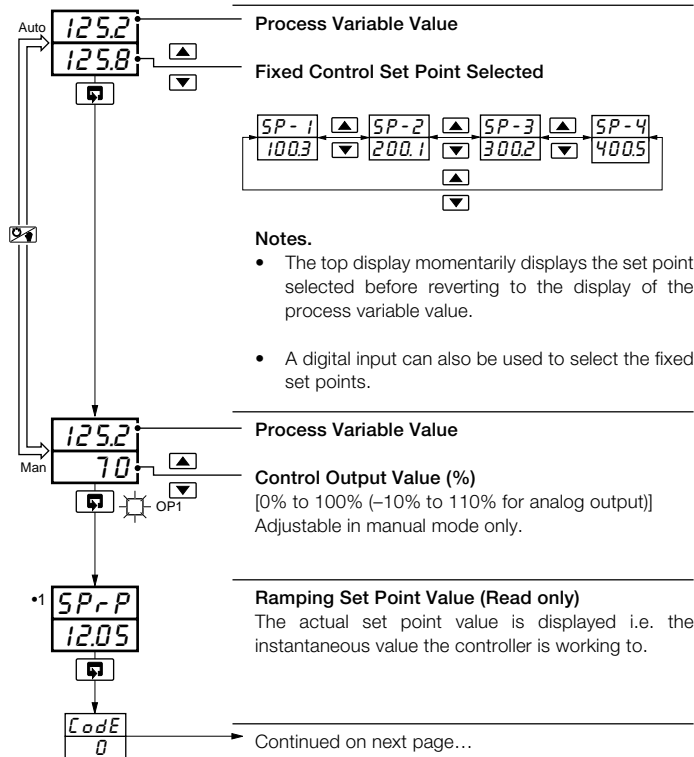

Notes.

- The top display momentarily displays the set point selected before reverting to the display of the process variable value.
- A digital input can also be used to select the fixed set points.

•1 Not displayed if the ramping set point facility is turned off – refer to Section 3.3.



...2.6 Multiple Fixed Set Points Controller

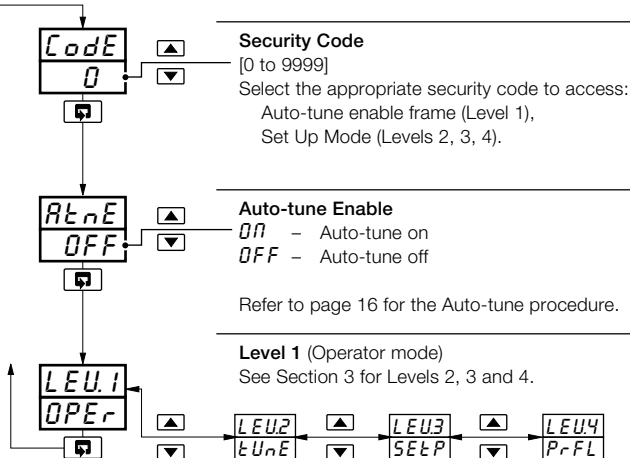



2.7 Auto-tune

Notes.

- Auto-tune optimizes process control by monitoring process performance and automatically updates the control parameters.
- Before starting auto-tune, the process variable must be stable ($\pm 2\%$ of engineering range).

1 - 'Start up' auto-tune (from manual mode)

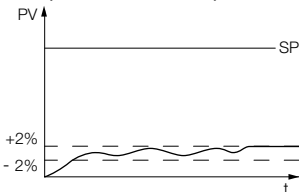

1a - Stable process before auto-tune

2 - 'At set point' auto-tune (from manual or automatic mode)

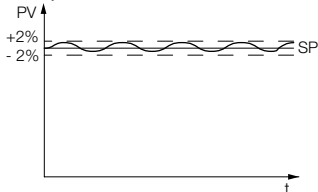

2a - Stable process before auto-tune

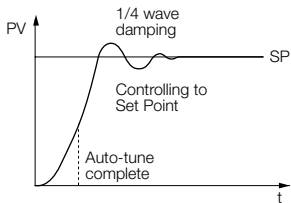

1b - Process response during auto-tune

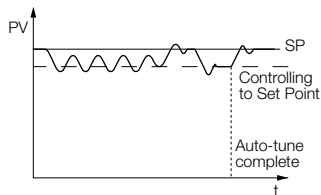

2b - Process response during auto-tune

Note. The time taken to complete autotune depends upon the system response time.

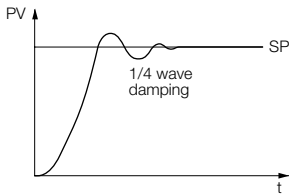

Typical process response after auto-tune

Fig 2.1 Typical Auto-tune Cycles



...2.7 Auto-tune

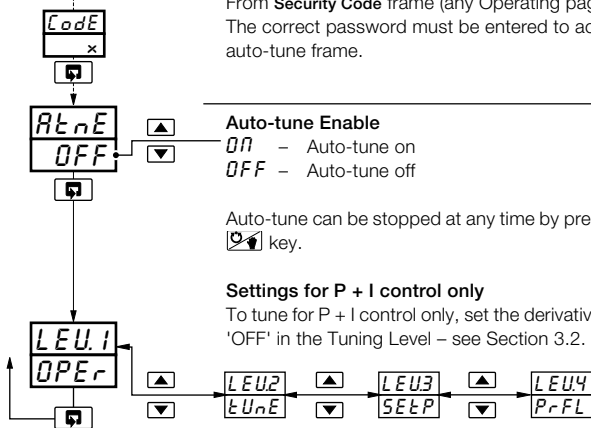

Notes.

- On completion the controller enters auto control mode and begins to control the process using the new PID values. For fine-tuning – see Section 3.
- For heat/cool control the cool proportional band is set to the same value as the heat proportional band (this value may need modification).
- If an error occurs during auto-tune, the controller reverts to manual mode with the control output set to the configured output value. An error message is displayed – see Table 2.1.

Error	Description	Error	Description
1	PV failed during auto-tune	7	A resultant P, I or D value was calculated out of range
2	Auto-tune has timed out during an auto-tune step	8	PV limit exceeded (At start up auto-tune)
3	Process too noisy to auto-tune	9	Controller put into configuration mode
4	Process too fast to auto-tune	10	Auto-tune terminated by user
5	Process too slow to auto-tune	11	PV is changing in the wrong direction during step test
6	PV deviated from set point by >25% eng. span during frequency response test		

Table 2.1 Auto-tune Error Codes

3.1 Introduction

To access the Set Up Mode (Levels 2, 3 and 4) the correct password must be entered in the security code frame (the default password code is 0). Refer to the fold-out sheet at the back of this manual for the contents of these levels.

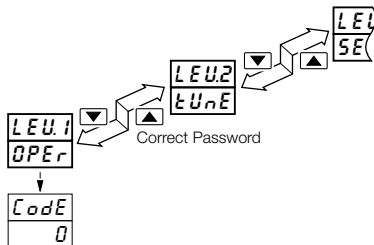

Refer to the fold-out sheet for the contents of each level

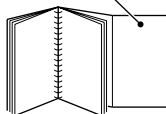

3.2 Tuning (Level 2)

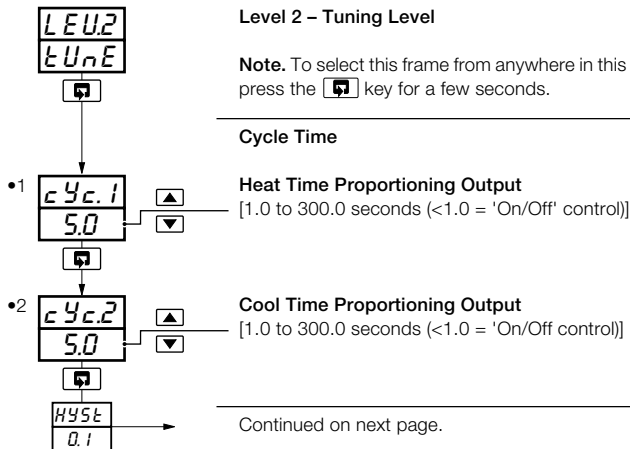

- 1 Displayed only if output 1 is assigned to a relay or logic output.
- 2 Displayed only if heat/cool hardware configuration is selected.



...3.2 Tuning (Level 2) – Fig. 3.2

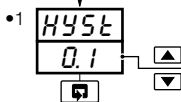

On/Off Hysteresis Value
(used for both heat and cool outputs)
[In engineering units]

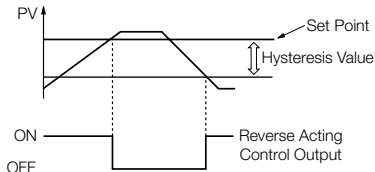

Proportional Band

Enter the proportional band value for the heat and cool outputs.

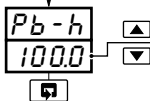

Heat Output (Output 1)
[0.1% to 999.9%]

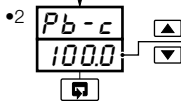

Cool Output (Output 2)
[0.1% to 999.9%]

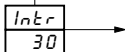

Continued on next page.

- 1 Displayed only if On/Off control is selected for either output.
- 2 Displayed only if heat/cool hardware configuration is selected.

...3.2 Tuning (Level 2)

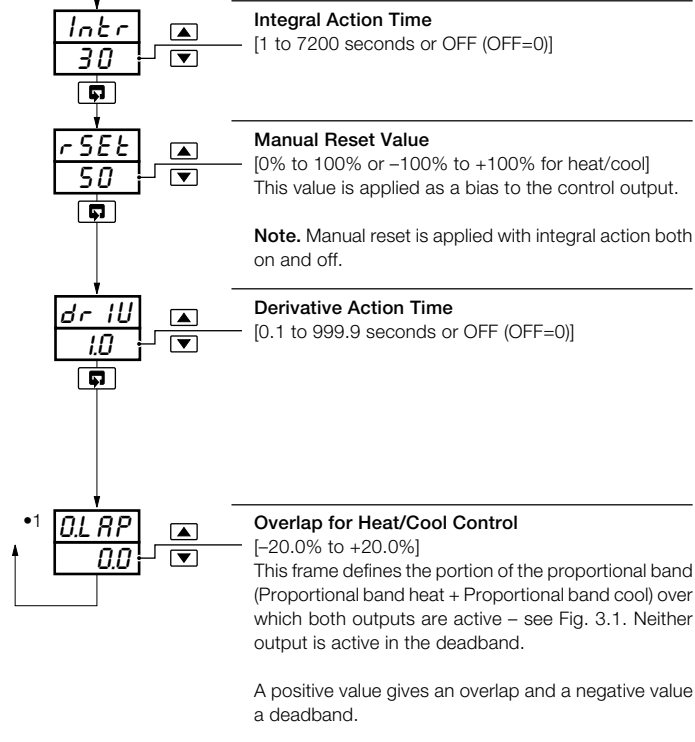

•1 Displayed only if a heat/cool hardware configuration is selected.

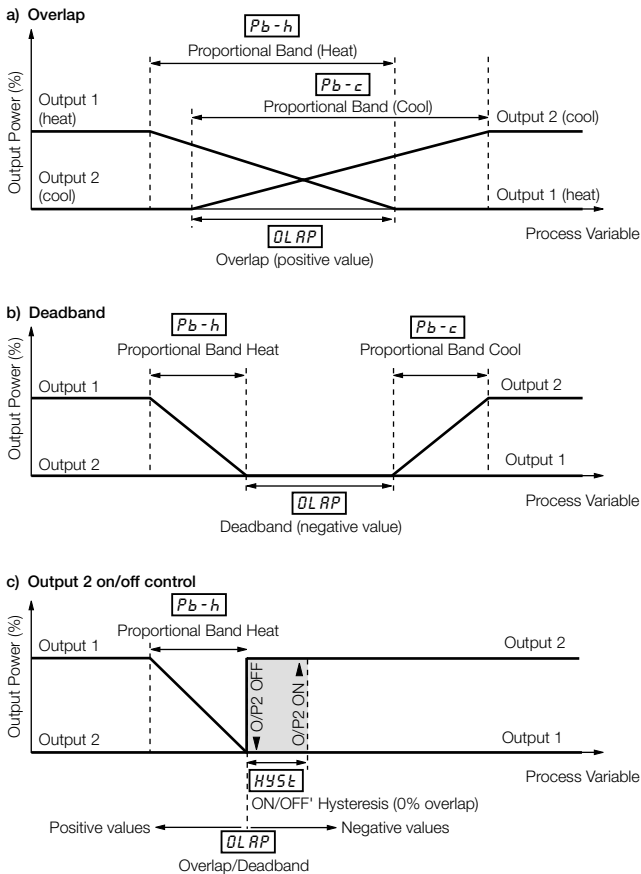
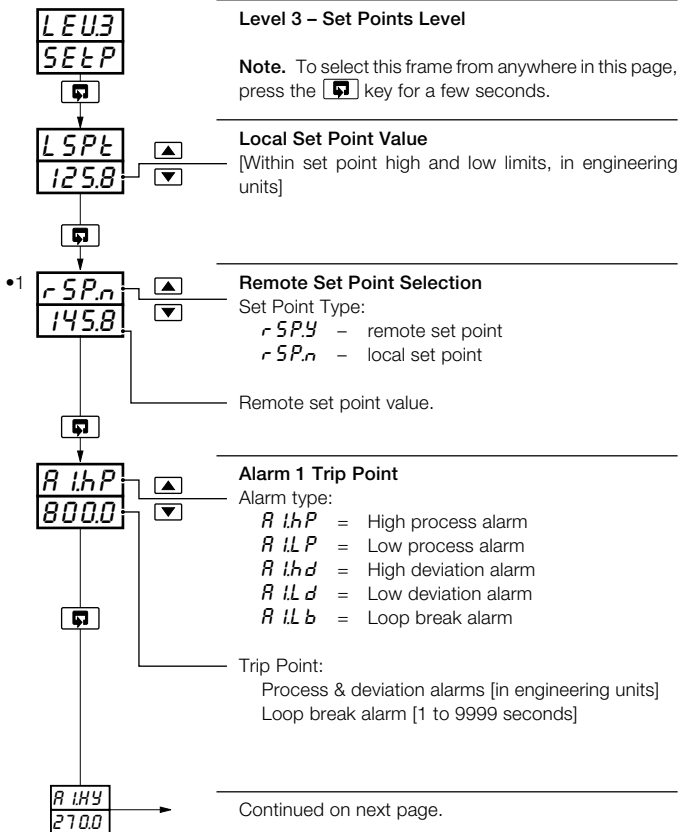

Fig. 3.1 Proportional Band & Deadband/Overlap – Heat/Cool Control Only

3.3 Set Points (Level 3)





...3.3 Set Points (Level 3)

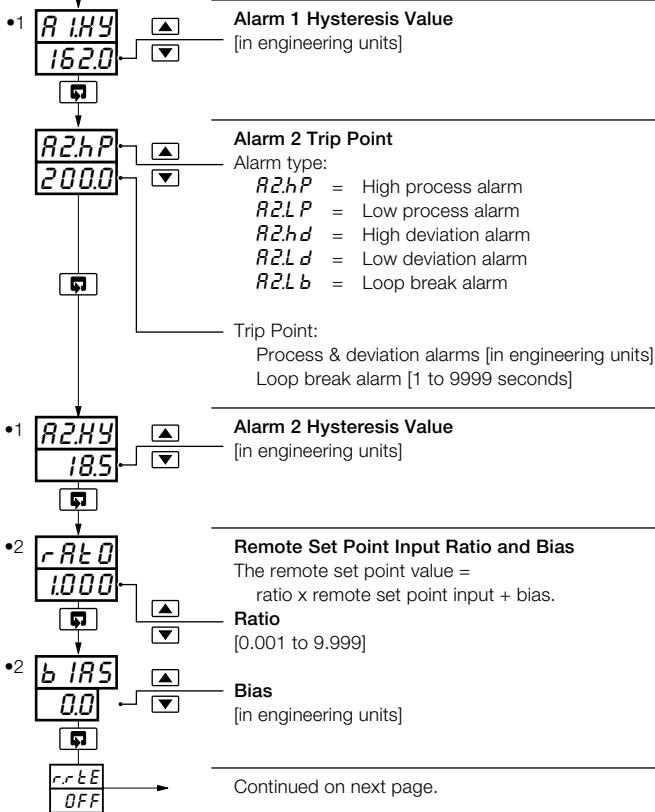

- 1 Displayed only if custom alarm hysteresis is selected – see section 4.3.2, not displayed if Loop Break Alarm type selected.
- 2 Displayed only if the remote set point option is selected.

...3.3 Set Points Level

r.r.tE
OFF

**Ramp Rate (for ramping set point facility)**

[1 to 9999 engineering units per hour, or OFF]

The ramping set point facility can be used to prevent a large disturbance to the control output when the set point value is changed. This applies only to the local and multiple fixed set points.

Note. For remote set points, the ramp rate is applicable only when switching from remote to local mode, not from local to remote.

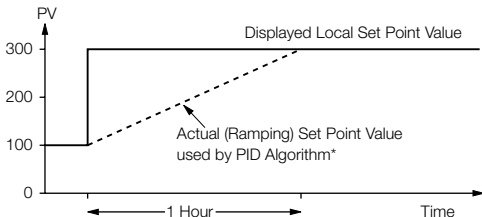

* e.g. Ramp Rate = 200 Increments/Hour

ORdJ
0.3

**Offset Adjustment**

An offset can be applied to the process variable input to enable spot calibration or the removal of system errors.

[±10% of engineering range in engineering units]



3.4 Profile (Level 4)

A four segment ramp/soak profile facility is provided. This level can be accessed only if the profile option is selected in the configuration level. The four segments are fixed as ramps or soaks as follows:

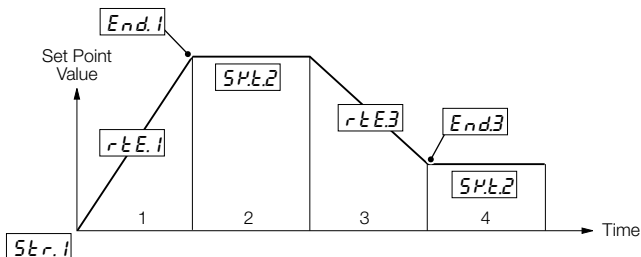

Level 4 – Profile Level

Note. To select this frame from anywhere in this page, press the key for a few seconds.

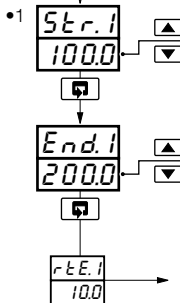

Start value for 1st Segment (ramp).

[Within display range (in engineering units)]

Enter the start value required.

End Value for 1st Segment (ramp).

[Within display range (in engineering units)]

Enter the end value required.

Continued on next page.

- 1 With the self-seeking set point facility enabled, the first ramp starts at the current process variable value instead of the start value for the 1st segment.

...3.4 Profile (Level 4)

•1 **rPtE.1**
40.00

**Ramp Rate for 1st Segment.**

[Engineering units*]

Enter the ramp rate required.

* The time option Eng Units/hr or Eng Units/min is set in the configuration level – see section 4.3.2.

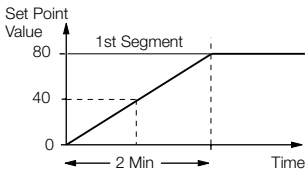

Example. Required Ramp Rate 40°C/min
Ramp Rate set to 40, Time Option set to 'Min' – see section 4.3.2

SPL.2
60.00

**Soak Time for 2nd Segment.**

[0 to 999.9 minutes or hours]*

End.3
100.0

**End Value for 3rd Segment (ramp).**

[Within display range (in engineering units)]

rPtE.3
20.00

**Ramp Rate for 3rd Segment.**

[Engineering units/hour or /minute]*

* Depending on the time option selected in the configuration level.

SPL.4
30.00

Continued on next page.

- 1 The engineering value is shown with an extra decimal place (up to a maximum of 3) for greater accuracy in setting the ramp rate.



...3.4 Profile (Level 4)

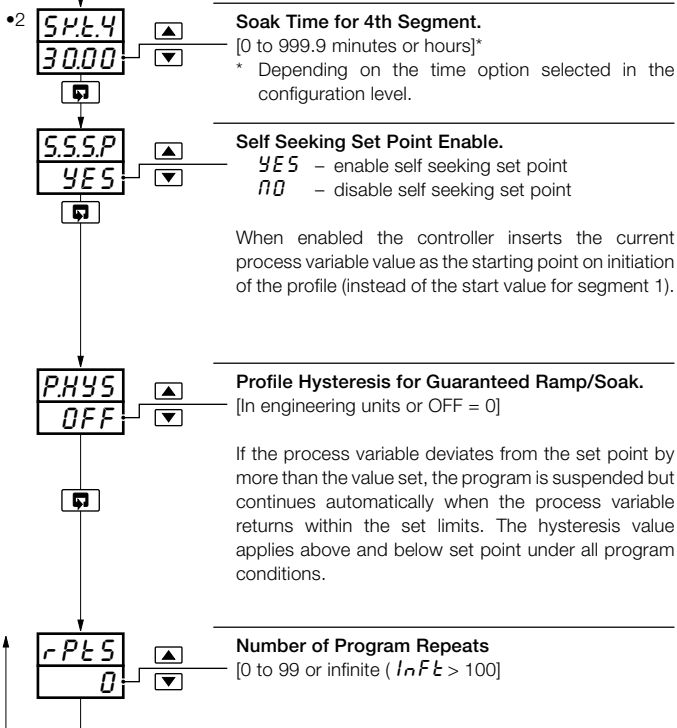

- 2 The engineering value is shown with an extra decimal place (up to a maximum of 3) for greater accuracy in setting the ramp rate.



4 CONFIGURATION MODE

4.1 Introduction

The Configuration Mode comprises two levels (5 and 6) as shown in Fig. 4.2.

Level 5 is divided into four frames. For most simple applications it is only necessary to set up the parameters in the first frame.

Note.

When in the configuration level:

- All the LED indicators flash.
- All relays and logic outputs are turned off.
- The analog output reverts to 0% (4mA) output level.

4.2 Accessing the Configuration Mode – Fig. 4.1

To access the Configuration Mode set the security switch to the 'Configure' position (levels 1 to 4 cannot be accessed from this setting). When the configuration parameters are programmed, reset the security switch to the 'Normal' position. The Operating page is displayed automatically.

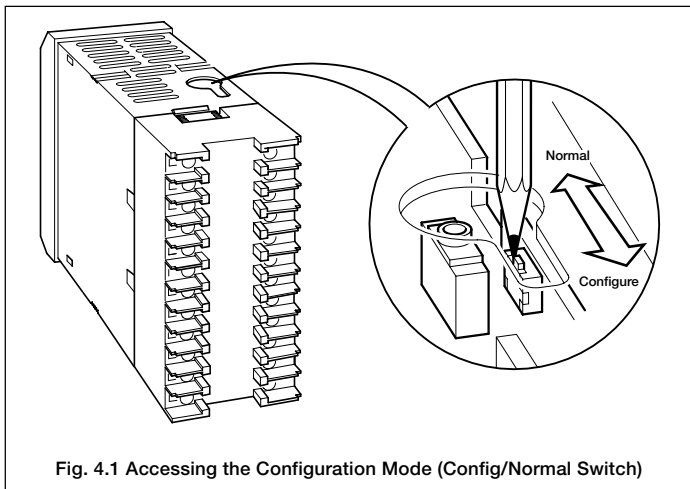

Fig. 4.1 Accessing the Configuration Mode (Config/Normal Switch)

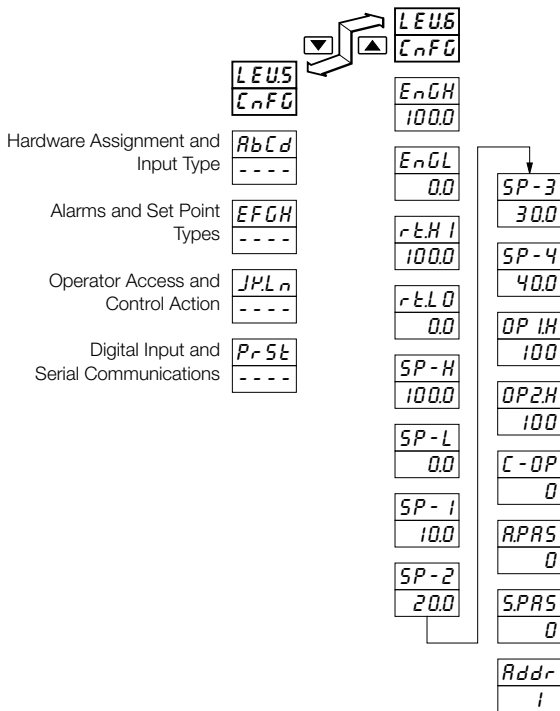
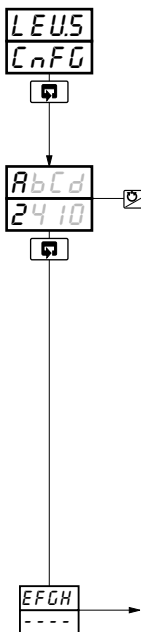

Fig. 4.2 Configuration Frames (Levels 5 and 6)



4.3 Basic Hardware and Configuration (Level 5)

4.3.1 Hardware Assignment and Input Type – Fig. 4.3



Level 5 – Configuration

Note. To select this frame from anywhere in this page, press the  key for a few seconds.

'ABCD' Settings

The parameter to be changed is indicated by the letter which is flashing. Parameter options are shown in Fig. 4.3.

A = Hardware configuration

b = Input type and range

C = Temperature units

d = Process variable display decimal places

Note 1. When the input type (parameter *b*) is changed, the range is set automatically to the maximum permissible for the input type selected.

Note 2. For custom settings, contact the local distributor.

Continued on page 32.



AbCd
24C0

A – Hardware Configuration

Freq.		Relay 1	Relay 2*	Relay 3*	Logic O/P	An. O/P	Control Type
50Hz	60Hz						
1	A	Output 1	Alarm 1	Alarm 2	Output 1	PV	Time Prop. or On/Off
2	b	Alarm 1	Alarm 2	None	None	Output 1	Analog Prop.
3	C	Output 1	Output 2	Alarm 1	Output 1	PV	Heat – Time Prop. Cool – Time Prop.
4	d	Output 2	Alarm 1	Alarm 2	Output 2	Output 1	Heat – Analog Cool – TP or On/Off
5	E	Alarm 1	Alarm 2	None	Output 1	PV	Alarm Unit or Logic O/P Time Prop.
U		Custom	Custom	Custom	Custom	Custom	Custom

* Available only if option board is fitted

AbCd
24C0

B – Input Type and Range Configuration

Display		Display	
b	THC Type B	1	0 to 20 mA
E	THC Type E	2	4 to 20 mA
J	THC Type J	3	0 to 5 V
K	THC Type K	4	1 to 5 V
n	THC Type N	6	0 to 50 mV
r	THC Type R	7	4 to 20 mA (square root lineariser)
S	THC Type S	U	Custom Configuration
t	THC Type T		
P	PT100 RTD		

AbCd
24C0

C – Temperature Units

Display	Temperature Units
C	Degrees C*
F	Degrees F*
0	No temperature units

* Temperature inputs only

AbCd
24C0

D – Process Variable Display
Decimal Places

Display	
0	xxxx
1	xxx . x
2	xx . xx
3	x . xxx

Fig. 4.3 Hardware Assignment and Input Type



4.3.2 Alarms and Set Point Types – Fig. 4.4

Note. All relays are **de-energised** in the alarm state.

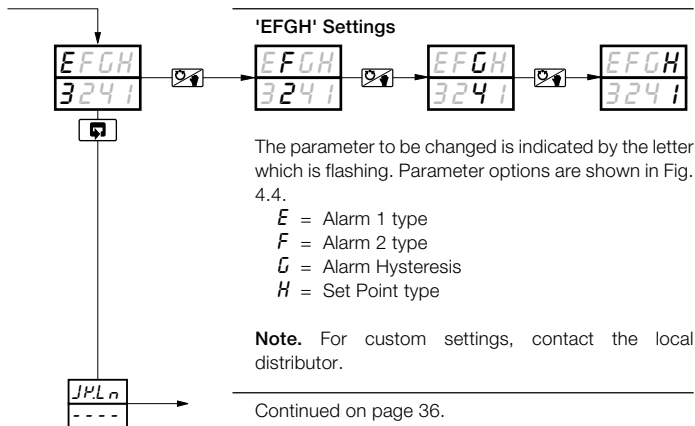



EFGH
3241

E – Alarm 1 Type*

Display	
0	None
1	High Process
2	Low Process
3	High Deviation
4	Low Deviation
5	Loop Break

EFGH
3241

F – Alarm 2 Type*

Display	
0	None
1	High Process
2	Low Process
3	High Deviation
4	Low Deviation
5	Loop Break

* Refer to Figs. 4.5 and 4.6 for alarm action

EFGH
3241

G – Alarm Hysteresis

Display	
0	None
1	0.1%
2	0.2%
3	0.5%
4	1.0%
5	2.0%
6	5.0%
U	Custom

} Value in % of
engineering
range

} Value in engineering units (See Note 1)

Note 1. When custom alarm hysteresis is selected, the alarm hysteresis values are set individually in the **set up level** – see section 3.3.

EFGH
3241

H – Set Point Type

Display	
0	Local Set Point Only
1	Local + Remote Set Point (no Remote Set Point Tracking)**
2	Local + Remote Set Point (with Remote Set Point Tracking)**
3	Multiple Fixed Set Points
4	Ramp/Soak (Time Units in Minutes)
5	Ramp/Soak (Time Units in Hours)

} (See Note 2)

**Available only if option board is fitted. Remote set point input is 4 to 20 mA

Note 2. With remote set point tracking enabled the local set point tracks the remote set point when in the remote set point mode.

Fig. 4.4 Alarms and Set Point Types



...4.3.2 Alarms and Set Point Types – Fig. 4.4

Note. All relays are **de-energised** in the alarm state.

Loop Break Alarm

The loop break alarm indicates a fault in the control loop (e.g. failure of a heating element in a furnace). If the control output remains at maximum or minimum for a time exceeding the trip value (in seconds) without any response in the process value, the loop break alarm is activated.

Process and Deviation Alarms (High/Low) – Figs 4.5 and 4.6

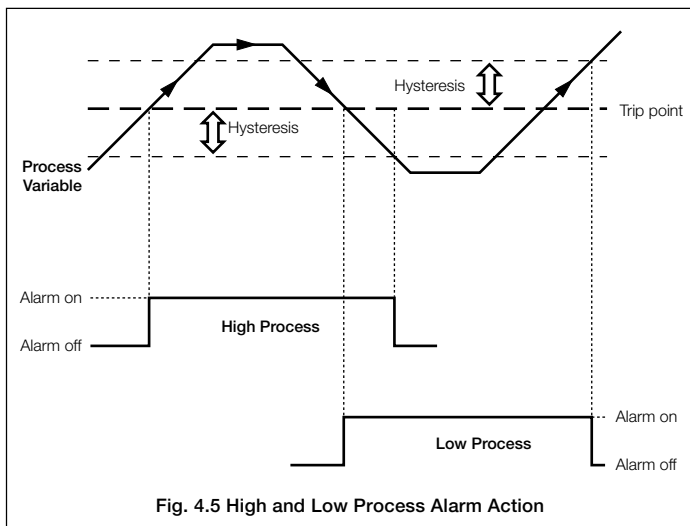

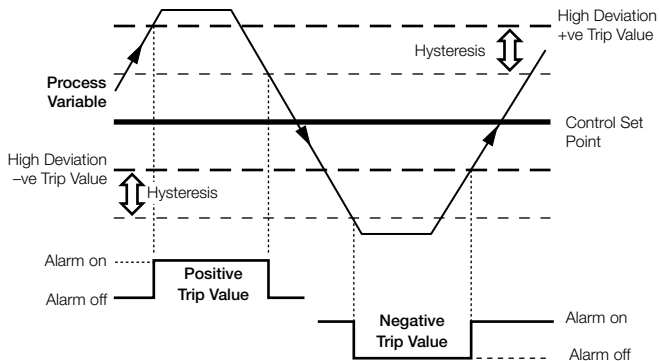

High Deviation Alarm

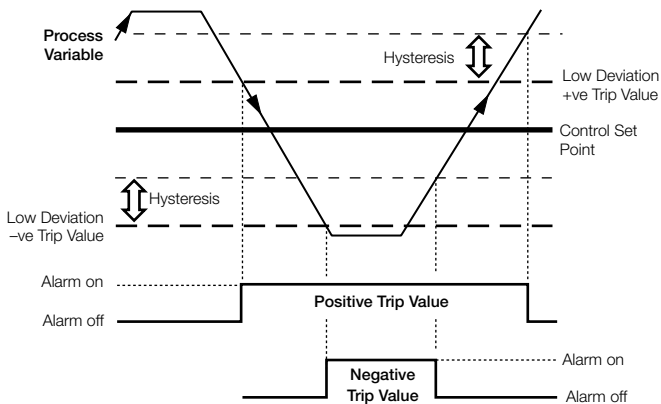

Low Deviation Alarm

Fig. 4.6 High and Low Deviation Alarm Action



4.3.3 Operator Access and Control Action – Fig. 4.7

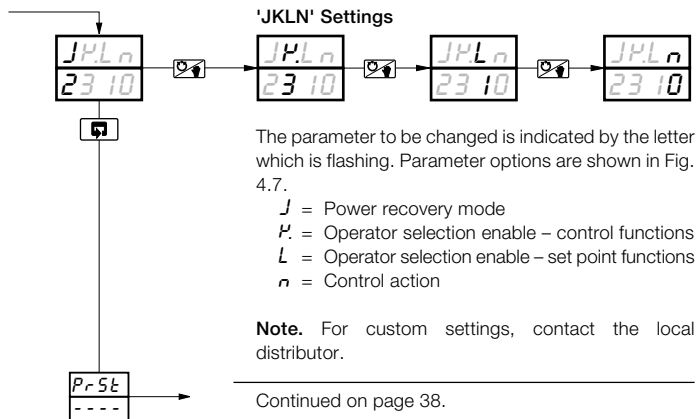



JPLn
23 10

J – Power Recovery Mode

Display	Mode
0	Last Mode
1	Manual with Last Output
2	Manual with 0.0% Output
3	Manual with 100.0% Output
4	Auto
U	Custom

JPLn
23 10

K – Operator Selection Enable Control Functions

Display	Auto/Manual and Autotune
0	Enable Both Functions
1	Disable A/M, Enable Auto-tune
2	Enable A/M, Disable Auto-tune
3	Disable Both Functions

JPLn
23 10

L – Operator Selection Enable – Set Point Functions

Display	Local Set Point Adjustment and Local/Remote Set Point Selection
0	Enable Both Functions
1	Disable Set Point Adjust, Enable Local/Remote Selection
2	Enable Set Point Adjust, Disable Local Remote Function
3	Disable Both Functions

JPLn
23 10

N – Control Action

Display	Heat Action	Cool Action
0	Reverse	Direct
1	Direct	Reverse

Fig. 4.7 Operator Access and Control Action



4.3.4 Digital Input and Serial Communications – Fig. 4.8

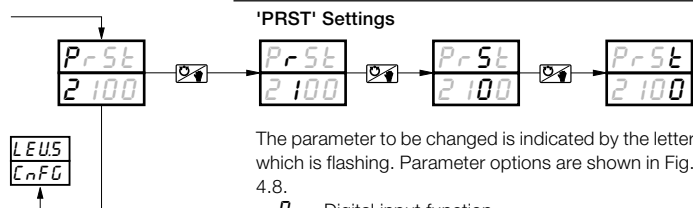

The parameter to be changed is indicated by the letter which is flashing. Parameter options are shown in Fig. 4.8.

- P* = Digital input function
- r* = Analog input digital filter
- S* = Serial communications configuration
- t* = Serial communication parity

Note. For custom settings, contact the local distributor.

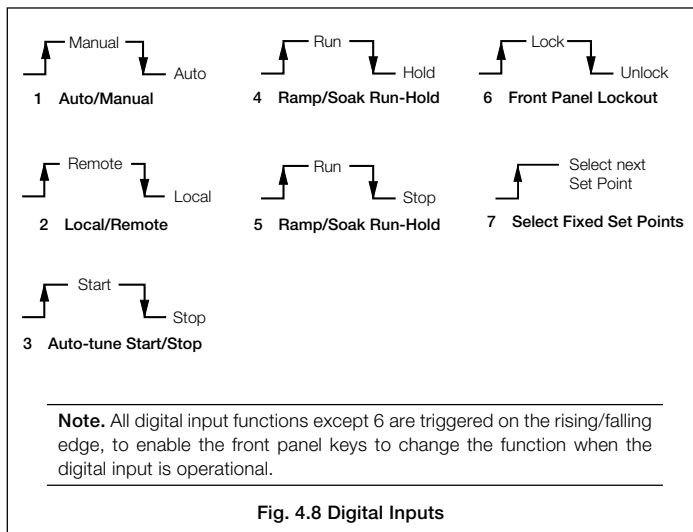

Fig. 4.8 Digital Inputs



P_rSt
2 100

P – Digital Input Functions

Display	Function
0	None
1	Auto/Manual
2	Local/Remote
3	Auto-tune Start
4	Ramp/Soak Run-Hold
5	Ramp/Soak Run-Stop
6	Front Panel Lockout
7	Select Fixed Set Points

P_rSt
2 100

R – Analog Input Digital Filter

Display	
0	0 seconds
1	1 second
2	2 seconds
5	5 seconds
8	10 seconds
8	20 seconds
ƒ	40 seconds
0.	60 seconds

Input filter averages the process
variable input values over the time set

P_rSt
2 100

S – Serial Communication Configuration

Display	Baud Rate, 2/4 Wire
0	Off
1	2400, 2 Wire
2	2400, 4 Wire
3	9600, 2 Wire
4	9600, 4 Wire

P_rSt
2 100

T – Serial Communications Parity

Display	
0	None
1	Odd
2	Even

Fig. 4.9 Digital Input and Serial Communications



4.4 Ranges and Passwords (Level 6)

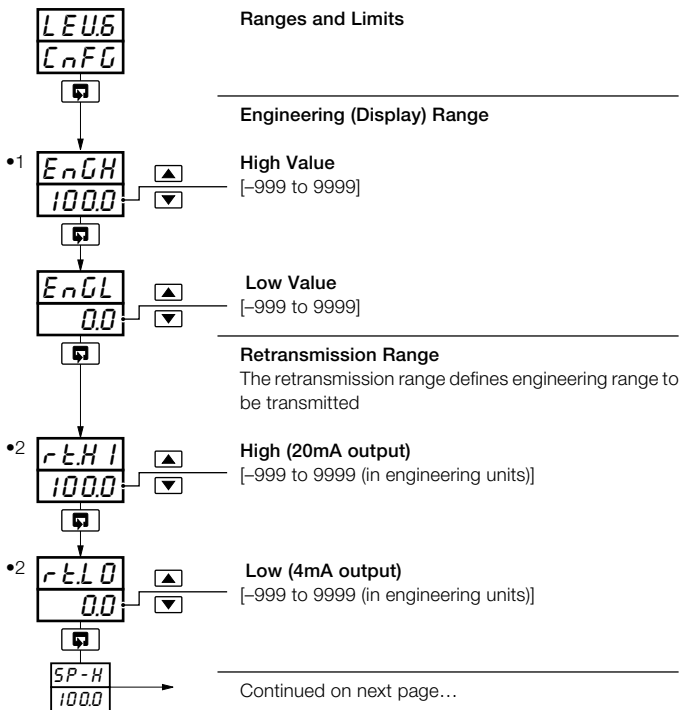

- 1 The engineering range high and low values are automatically set to the maximum allowed value when thermocouple or RTD is selected in the configuration level – see Section 4.3.1. This value can be modified if required.
- 2 Displayed only if the analog output is configured to retransmit the process variable or control set point value.



...4.4 Ranges and Passwords (Level 6)

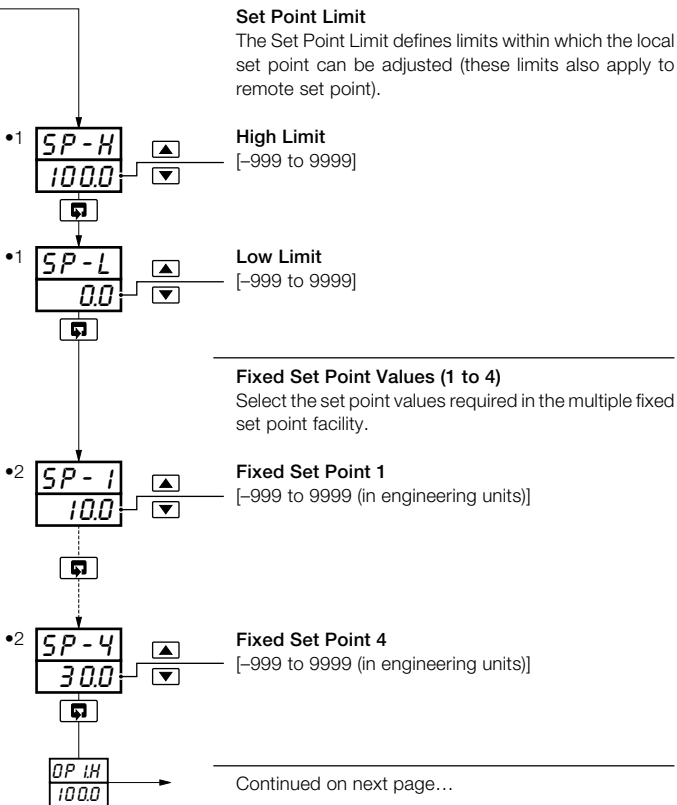

- 1 This limit applies to the local and remote set point values.
- 2 Displayed only if the multiple fixed set point facility is selected.



...4 CONFIGURATION MODE

...4.4 Ranges and Passwords (Level 6)

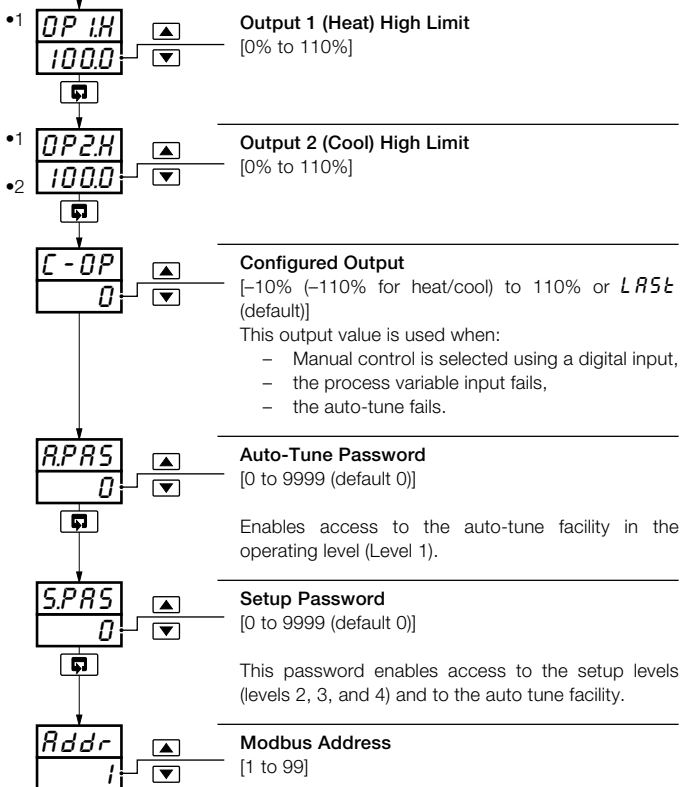

This frame allows the Modbus address to be set.

- 1 This value applies only in automatic mode.
The low limit is automatically set to 0.0% (-10% for analog outputs).
- 2 Displayed only if a heat/cool hardware configuration is selected.



5 INSTALLATION

EC Directive 89/336/EEC

In order to meet the requirements of the EC Directive 89/336/EEC for EMC regulations, this product must not be used in a non-industrial environment.

End of Life Disposal

This instrument does not contain any substance that will cause undue harm to the environment. It can therefore be safely considered as normal waste and disposed of accordingly.

Cleaning

Clean the front panel only, using warm water and a mild detergent.



5.1 Siting – Figs. 5.1 and 5.2

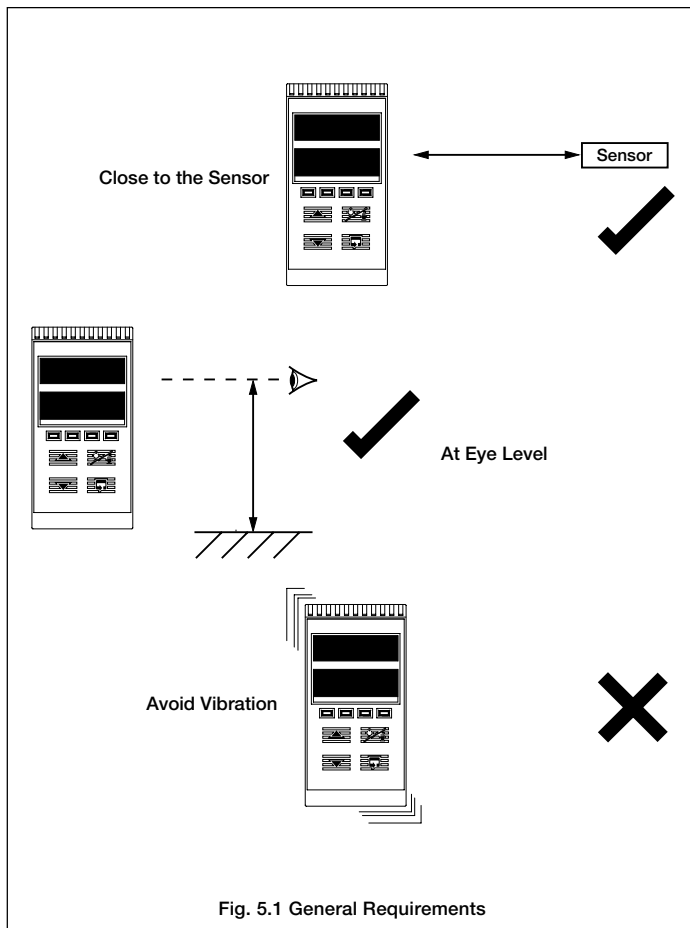



...5.1 Siting – Figs. 5.1 and 5.2

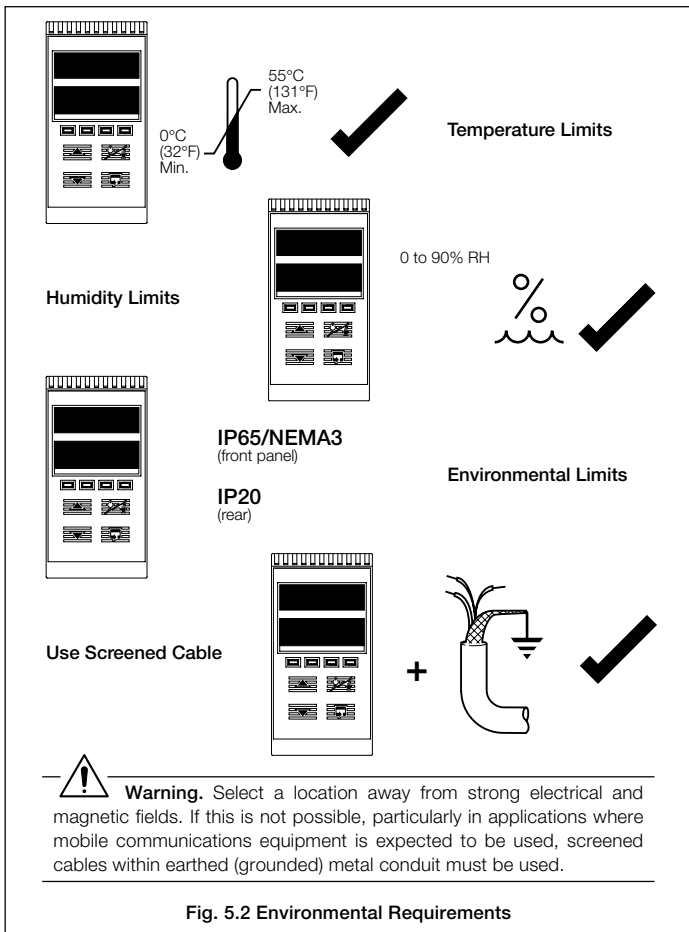



..5.2 Mounting – Figs. 5.3 and 5.4

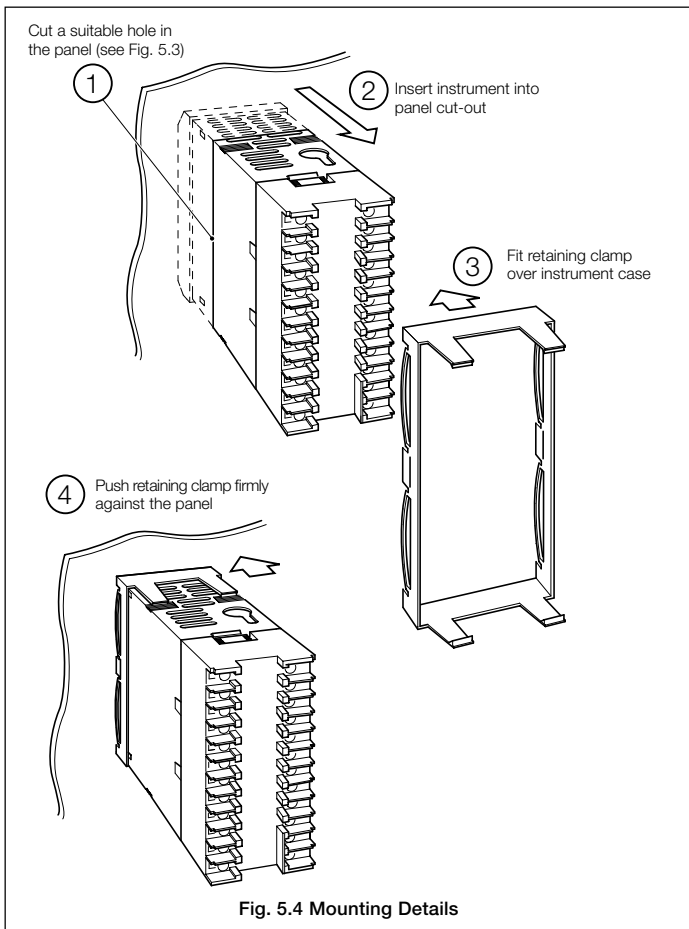



5.3 Electrical Connections – Fig. 5.5

**Warning.**

- The instrument is not fitted with a switch therefore a disconnecting device such as a switch or circuit breaker conforming to local safety standards must be fitted to the final installation. It must be mounted in close proximity to the instrument within easy reach of the operator and must be marked clearly as the disconnection device for the instrument
 - Remove all power from supply, relay and any powered control circuits and high common mode voltages before accessing or making any connections.
 - Use cable appropriate for the load currents. The terminals accept cables up to 14AWG (2.5mm²).
 - The instrument conforms to Mains Power Input Insulation Category 2, Pollution Degree 2 (EN601010-1).
 - All connections to secondary circuits must have basic insulation.
 - After installation, there must be no access to live parts, e.g. terminals
 - Terminals for external circuits are for use only with equipment with no accessible live parts.
 - If the instrument is used in a manner not specified by the Company, the protection provided by the equipment may be impaired.
 - All equipment connected to the instrument's terminals must comply with local safety standards (IEC 60950, EN601010-1).
-

Note.

- Always route signal leads and power cables separately, preferably in earthed (grounded) metal conduit.
 - It is strongly recommended that screened cable is used for signal inputs and relay connections.
-



This equipment is protected through double insulation (Class II).

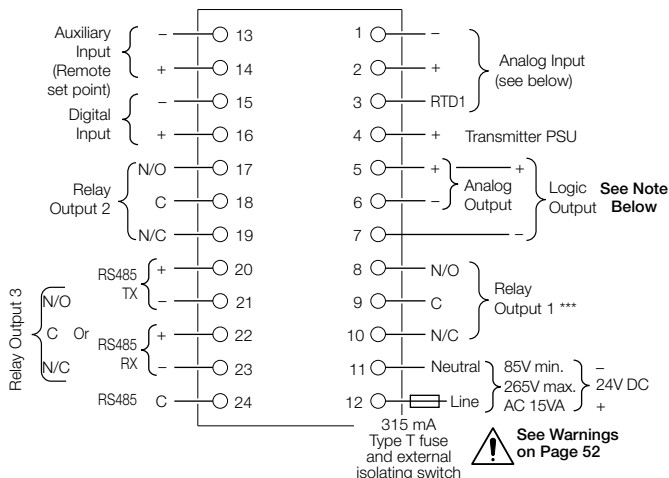

Note. The Analog Output and Logic Output use a common positive terminal that is capable of driving both outputs simultaneously.

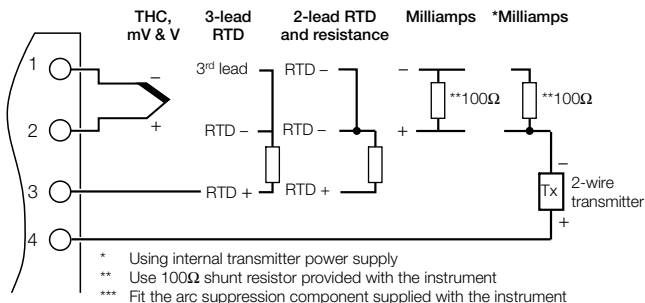

Fig. 5.5 Electrical Connections



5.4 Relays, Arc Suppression and Outputs

5.4.1 Relay Contact Ratings

Relay contacts are rated at:

115/230V AC at 5A (non-inductive).

250V DC 25W max.

A suitable fuse must be fitted.

5.4.2 Arc Suppression

Arc suppression components are fitted to relays 2 and 3 only. If relay 1 is required to switch inductive loads, fit the arc suppression components supplied.

5.4.3 Logic Output

18V DC at 20mA.

Min load 900 Ω .

Isolated from Analog Output (not isolated from Retransmission Output).

Dielectric strength – 500V DC for 1 minute.

5.4.4 Control or Retransmission Analog Outputs

Max. load 15V (750 Ω at 20mA).

Isolated from Analog Output (not isolated from Logic Output).

Dielectric strength – 500V DC for 1 minute.

5.4.5 Digital Input

Type: Volt-free

Minimum Pulse: 250ms

SPECIFICATION

Summary

- P, PI, PID single loop controller
- Autotune facility
- Fully user configurable
- Hoseproof front face

Operation

Display

- High-intensity 7-segment, 2 x 4-digit LED display
- Display range -999 to +9999
- Display resolution ± 1 digit
- Display height 10mm (0.39 in.)

Configuration

- User defined via front panel or PC Configurator

Standard Functions

Control types

- Programmable for manual, on/off, time proportioning, current proportioning and heat/cool control.

Set points

- Local
- Remote
- 4 selectable fixed value
- Ramping set point

Profile controller

- Number 4 ramp/soak segments
- Features Guaranteed ramp/soak, self seeking set point, program repeat
- Controls Run, hold and stop from front panel switches
Run/hold or run/stop from digital input

Alarms

- Number Two user-defined
- Type High/low process
High/low deviation
Loop break alarm

...SPECIFICATION

Analog Inputs

Number

One as standard

One optional (4 to 20mA remote set point input)

Input sampling rate

250ms per channel

Type

Universally configurable to provide (Channel 1 only):

Thermocouple (THC)

Resistance Thermometer (RTD)

Millivolt

Current

DC voltage

Input impedance

mA100 Ω

mV, V >10M Ω

Linearizer functions

Programmable for standard inputs:

SqRoot, THC types B, E, J, K, N, R, S, T or Pt100

Broken sensor protection

Upscale drive on THC and RTD

Downscale drive on milliamps and voltage

Cold junction compensation

Automatic CJC incorporated as standard

Stability <0.05°C/°C change in ambient temperature

Input protection

Common mode isolation >120dB at 50/60Hz with 300 Ω imbalance

Series mode rejection >60dB 50/60Hz

Transmitter power supply

24V, 30mA max. powers one 2-wire transmitter

Standard Analog Input Ranges

Thermocouple	Maximum Range °C	Maximum Range °F	Accuracy (% of reading)
B	-18 to 1800	0 to 3270	0.25% or $\pm 2^{\circ}\text{C}$ (above 200°C)
E	-100 to 900	-140 to 1650	0.25% or $\pm 0.5^{\circ}\text{C}$
J	-100 to 900	-140 to 1650	0.25% or $\pm 0.5^{\circ}\text{C}$
K	-100 to 1300	-140 to 2350	0.25% or $\pm 0.5^{\circ}\text{C}$
N	-200 to 1300	-325 to 2350	0.25% or $\pm 0.5^{\circ}\text{C}$
R	-18 to 1700	0 to 3000	0.25% or $\pm 1.0^{\circ}\text{C}$ (above 300°C)
S	-18 to 1700	0 to 3000	0.25% or $\pm 0.5^{\circ}\text{C}$ (above 200°C)
T	-250 to 300	-400 to 550	0.25% or $\pm 0.5^{\circ}\text{C}$

RTD	Maximum Range °C	Maximum Range °F	Accuracy (% of reading)
PT100	-200 to 600	-325 to 1100	0.25% or $\pm 0.5^{\circ}\text{C}$

Linear Inputs	Range	Accuracy (% of reading)
Milliamps	0 to 20	0.25% or $\pm 2\mu\text{A}$
Milliamps	4 to 20	0.25% or $\pm 2\mu\text{A}$
Volts	0 to 5	0.25% or $\pm 200\mu\text{V}$
Volts	1 to 5	0.25% or $\pm 200\mu\text{V}$
Millivolts	0 to 50	0.25% or $\pm 20\mu\text{V}$

Square Root Input	Range	Accuracy (% of reading)
Milliamps	4 to 20	0.25% or $\pm 2\mu\text{A}$

Notes.

Performance accuracy is not guaranteed at extreme low end of thermocouple and sq. root ranges.
 RTD, 3-wire platinum, 100Ω per DIN 43760 standard (IEC751), with range of 0 to 400Ω .

Min. span below zero Type T $70^{\circ}\text{C}/126^{\circ}\text{F}$
 Type N $105^{\circ}\text{C}/189^{\circ}\text{F}$
 THC standards DIN 43710 IEC 584
 RTD standards DIN 43760 IEC 751

...SPECIFICATION

Outputs

Control output/retransmission

Analog, configurable in the range of 4 to 20mA

Max. load 15V (750 Ω at 20mA)

Accuracy $\leq 0.25\%$ of span

Dielectric 500V DC from I/P (not isolated from logic O/P)

Logic output

18V DC at 20mA

Min. load 400 Ω

Dielectric 500V DC from I/P (not isolated from control O/P)

Relay output

One relay as standard (SPDT) (5A @ 115/230V AC)

Options

One option board can be installed from:

Type 1 One relay

Type 2 Two relays + one digital input + remote set point

Type 3 One relay + one digital input + remote set point + Modbus serial communications

Relay output

SPDT 5A @ 115/230V AC

Digital input

Type Volt-free

Minimum pulse 250ms (not isolated from remote set point)

Modbus serial communications

Connections RS422/485, 2 or 4-wire

Speed 2.4k or 9.6k baud rate

Protocol Modbus RTU slave

Remote Set Point Input

4 to 20 mA DC, 100 Ω nominal input impedance

Preset to process variable engineering units
(not isolated from digital inputs)

Physical**Size**

48 wide x 96 high x 125mm (1.89 in. wide x 3.78 in. high x 4.92 in.)

Weight

250g (0.5lb) approximate

Electrical**Voltage**

85 to 265V AC (50/60Hz)

24V DC

Power consumption

< 6VA

Environmental**Operating limits**

0 to 55°C (32 to 131°F)

5 to 95%RH non-condensing

Temperature stability

< 0.02% of reading or 2 μ V/°C (1 μ V/°F)

Front face

IP65 (NEMA3), case rear IP20

EMC**Emissions**

Meets requirements of EN50081-2

Immunity

Meets requirements of EN50082-2

Design and manufacturing standards

CE Mark

Safety standards

EN61010 – 1

C22.2 No. 1010

UL 310 – 1

FM 3810

Customer Support

We provide a comprehensive after sales service via our Worldwide Service Organization. Contact one of the following offices for details of your nearest Service and Repair Centre.



Client Warranty

Prior to installation, the equipment referred to in this manual must be stored in a clean, dry environment, in accordance with the Company's published specification. Periodic checks must be made on the equipment's condition.

In the event of a failure under warranty, the following documentation must be provided as substantiation:

1. A listing evidencing process operation and alarm logs at time of failure.
2. Copies of all storage, installation, operating and maintenance records relating to the alleged faulty unit.

CUSTOMER SETUP LOG

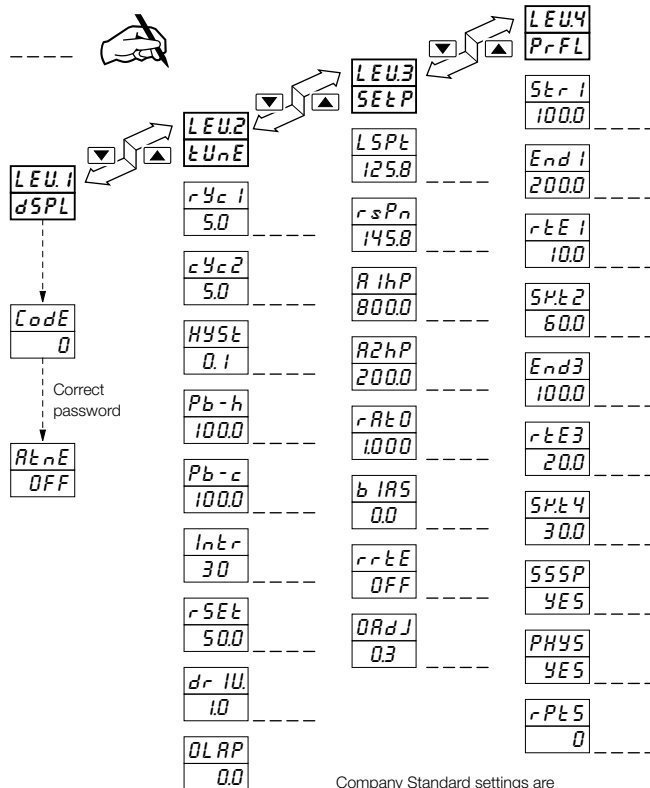

Company Standard settings are shown in the lower display

Instrument Serial Number: _____

Product Code: C 1 0 0 / _ _ _ / _ _ _



CUSTOMER CONFIGURATION LOG

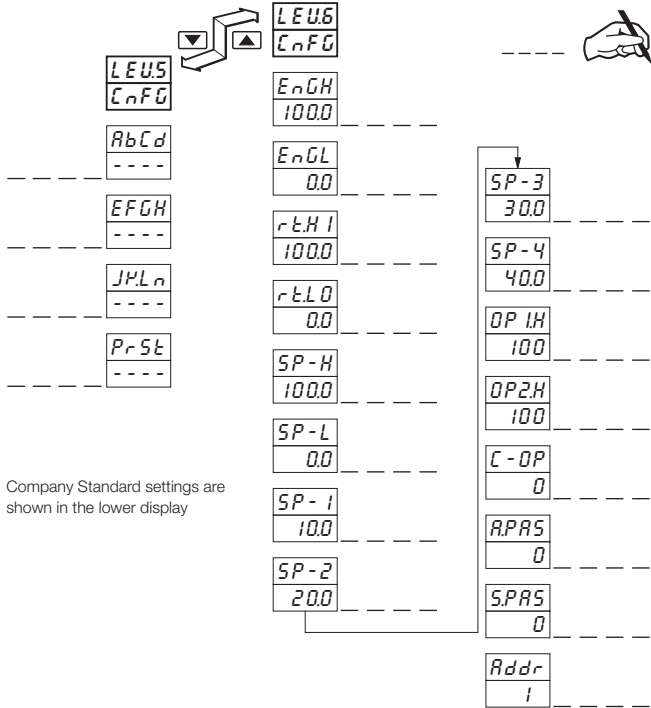

Company Standard settings are shown in the lower display

Distributed by

Instrumentation
Systems & Services Ltd

PO Box 1 • Ilkley • West Yorkshire • LS29 8EU
Phone: 01943 602001 • Fax: 01943 816796
Website: www.issltd.co.uk • Email: sales@issltd.co.uk

IM/C100 Issue 10

ABB has Sales & Customer Support expertise in over 100 countries worldwide

The Company's policy is one of continuous product improvement and the right is reserved to modify the information contained herein without notice.

Printed in UK (07.05)

© ABB 2005

