

PO Box 1 • Ilkley • West Yorkshire • LS29 8EU
Phone: 01943 602001 • Fax: 01943 816796
Website: www.issltd.co.uk • Email: sales@issltd.co.uk



Instrumentation
Systems & Services Ltd



ABB











Electrical Safety

This equipment complies with the requirements of BS EN 61010-1:2001-2 "Safety Requirements for Electrical Equipment for Measurement, Control and Laboratory Use". If the equipment is used in a manner NOT specified by the Company, the protection provided by the equipment may be impaired.

Symbols

One or more of the following symbols may appear on the equipment labelling:

	Warning – Refer to the manual for instructions		Direct current supply only
	Caution – Risk of electric shock		Alternating current supply only
	Protective earth (ground) terminal		Both direct and alternating current supply
	Earth (ground) terminal		The equipment is protected through double insulation

Information in this manual is intended only to assist our customers in the efficient operation of our equipment. Use of this manual for any other purpose is specifically prohibited and its contents are not to be reproduced in full or part without prior approval of the Technical Publications Department.

Health and Safety

To ensure that our products are safe and without risk to health, the following points must be noted:

1. The relevant sections of these instructions must be read carefully before proceeding.
2. Warning labels on containers and packages must be observed.
3. Installation, operation, maintenance and servicing must only be carried out by suitably trained personnel and in accordance with the information given.
4. Normal safety precautions must be taken to avoid the possibility of an accident occurring when operating in conditions of high pressure and/or temperature.
5. Chemicals must be stored away from heat, protected from temperature extremes and powders kept dry. Normal safe handling procedures must be used.
6. When disposing of chemicals ensure that no two chemicals are mixed.

Safety advice concerning the use of the equipment described in this manual or any relevant hazard data sheets (where applicable) may be obtained from the Company address on the back cover, together with servicing and spares information.



GETTING STARTED

This manual is divided into 5 sections which contain all the information needed to install, configure, commission and operate the COMMANDER 150. Each section is identified clearly by a symbol as shown below.



Displays and Controls

- Displays and function keys
- LED Indication
- Error Messages



Operator Mode (Level 1)

- Operator menus for:
 - *Standard Indicator*
 - *Totalizer/Batch Controller*
 - *Maximum/Minimum/Average Indicator*



Set Up Mode (Level 2)

- Alarm trip points
- Totalizer functions



Configuration Mode (Levels 3 and 4)

- Accessing the configuration levels
- Level 3
 - Hardware assignment and input type
 - Alarm types and hysteresis
 - Operator functions and totalizer setup
 - Digital input and serial communications
- Level 4
 - Ranges and passwords



Installation

- Siting
- Mounting
- Electrical connections

Symbol Identification and Section Contents

CONTENTS

GETTING STARTED	1
1 DISPLAYS AND FUNCTION KEYS	3
1.1 Introduction	3
1.2 Use of Function Keys	4
1.3 LED Alarms and Indicators	5
1.4 Error Messages	6
2 OPERATOR MODE	7
2.1 Introduction	7
2.2 Operating Page – Standard (Level 1)	8
2.3 Operating Page – Totalizer (Level 1)	9
2.4 Operating Page – Maths Functions (Level 1)	11
3 SET UP MODE	13
3.1 Introduction	13
3.2 Setup Level (Level 2)	14
4 CONFIGURATION MODE	18
4.1 Introduction	18
4.2 Accessing the Configuration Mode	18
4.3 Basic Hardware and Configuration (Level 3)	20
4.3.1 Hardware Assignment and Input Type	20
4.3.2 Alarms	22
4.3.3 Operator Functions and Totalizer Set Up	24
4.3.4 Digital Input and Serial Communications	26
4.4 Ranges and Passwords (Level 4)	28
5 INSTALLATION	31
5.1 Siting	32
5.2 Mounting	34
5.3 Electrical Connections	36
5.4 Relays, Arc Suppression, Inputs and Outputs	38
5.4.1 Relay Contact Ratings	38
5.4.2 Arc Suppression	38
5.4.3 Logic Output	38
5.4.4 Retransmission Analog Output	38
5.4.5 Digital Input	38
SPECIFICATION	39



1 DISPLAYS AND FUNCTION KEYS

Note.

The fold-out page attached to the back cover of this manual shows all frames in the programming levels. Space is provided next to each frame to record programmed settings/selections.

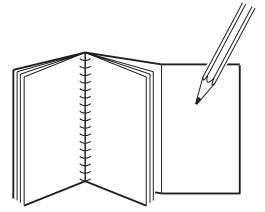

1.1 Introduction – Fig. 1.1

The COMMANDER 150 front panel display, function keys and LED indicators are shown in Fig. 1.1.

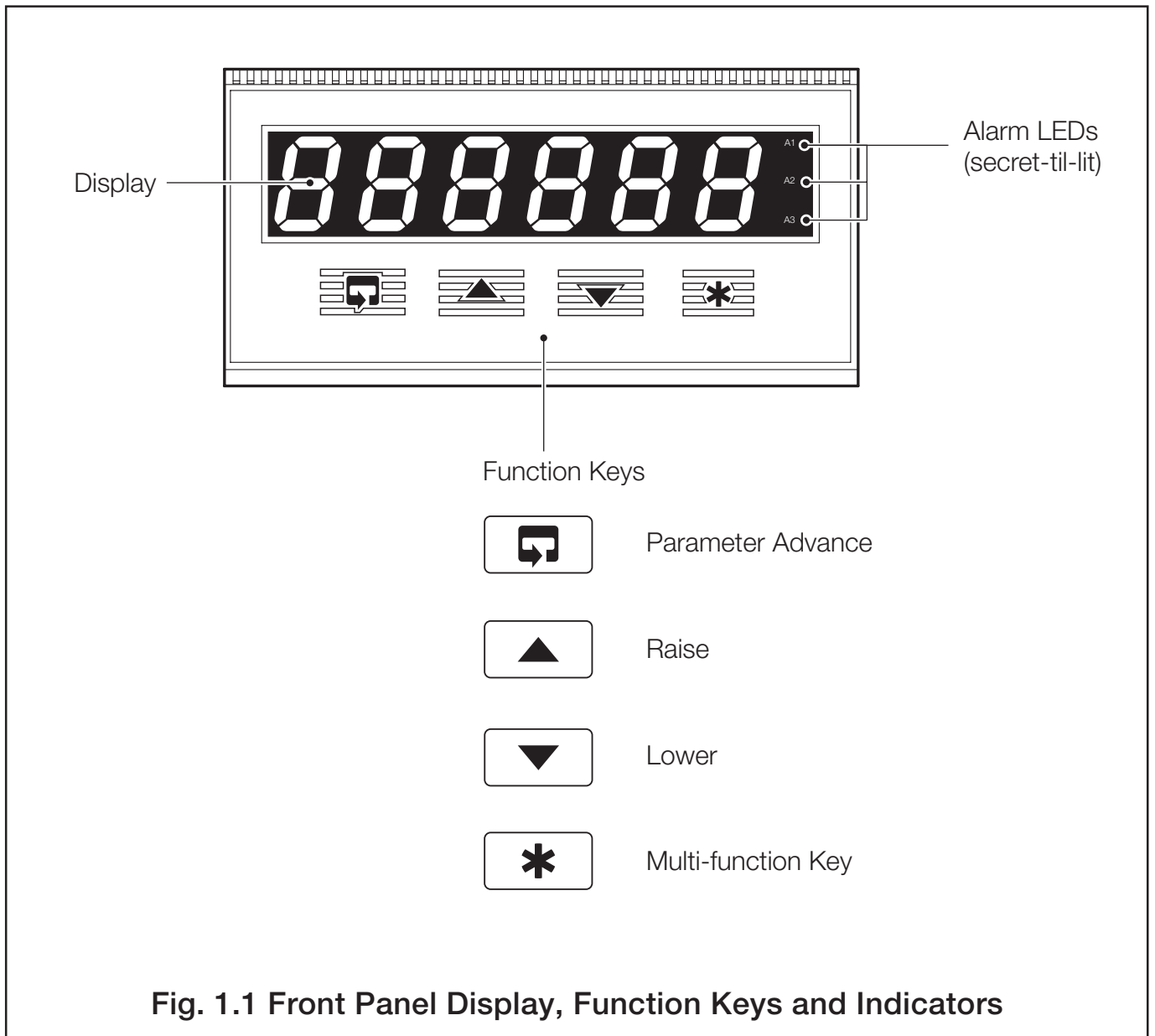

1.2 Use of Function Keys – Fig. 1.2

A – Raise and Lower Keys

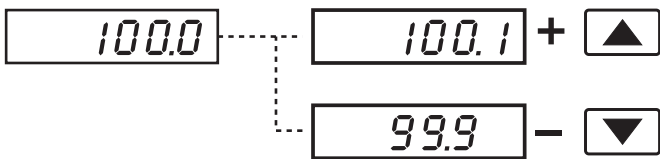

Use to change/set a parameter value...

or...

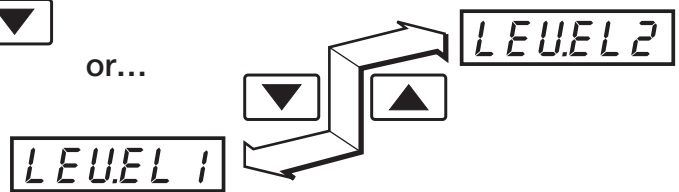

...move between levels

B – Parameter Advance Key

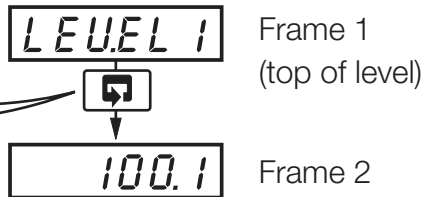

Use to advance to the next frame within a level...

or...

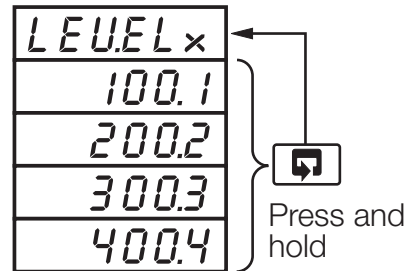

...select the top (LEVEL) frame from within a level

Note. This key also stores any changes made in the previous frame

C – Multi-function Key

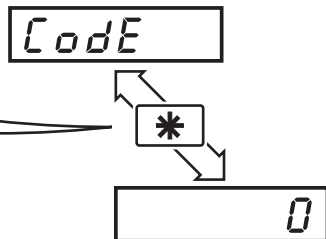

Use to view a parameter setting or selection...

or...

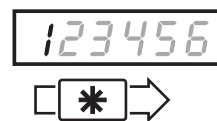

...select individual characters in a frame

Fig. 1.2 Use of Function Keys

1.3 LED Alarms and Indicators

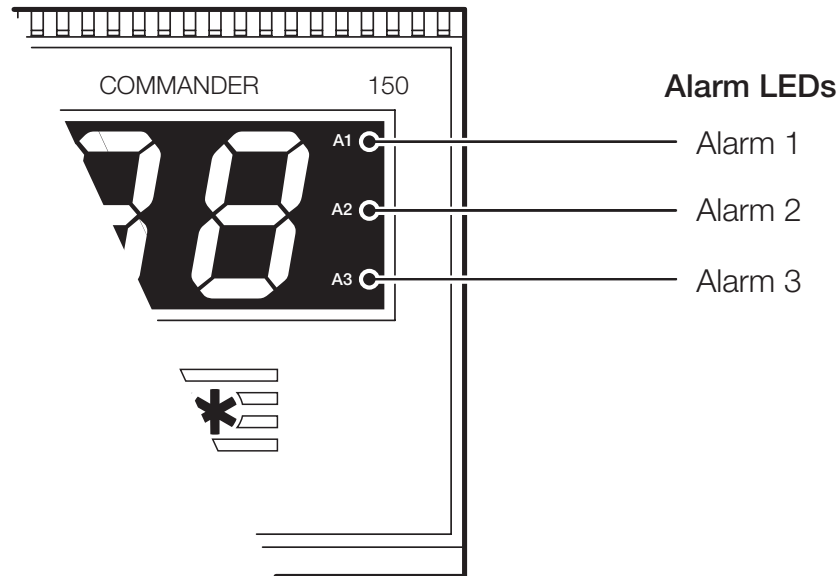

LED Status

All Flashing







- Indicator is in the configuration mode – see Section 4.2.

A1, A2 and A3

- Flashes when Alarm is active (off when inactive).
- Lit constantly when Alarm 1 is an active latched alarm which has been acknowledged

Fig. 1.3 LED Alarms and Indicators

1.4 Error Messages

Display	Error/Action	To Clear Display
	Calibration error Turn mains power off and on again (if the error persists contact the Service Organization).	Press the  key
	Configuration error The configuration and/or setup data for the instrument is corrupted. Turn mains power off and on again (if error persists, check configuration/setup settings).	Press the  key
	A to D Converter fault The analog to digital converter is not communicating correctly.	Turn mains power off and on again. If the problem persists, contact the Service Organization
	Process Variable Over/Under Range	Restore valid input.
	Option board error Communications to the option board have failed.	Contact the Service Organization



2 OPERATOR MODE

2.1 Introduction

Operator Mode (Level 1) is the normal day-to-day mode of the COMMANDER 150.

Frames displayed in level 1 are determined by the indicator functions which are selected during configuration of the instrument – see Section 4.

Note. Only the operating frames relevant to the configured functions are displayed in Operator Mode.

The three indicator functions are:

- **Standard Indicator** – page 8
- **Indicator with Totalization** – page 9
- **Indicator with Max./Min./Average** – page 11



2.2 Operating Page – Standard (Level 1)

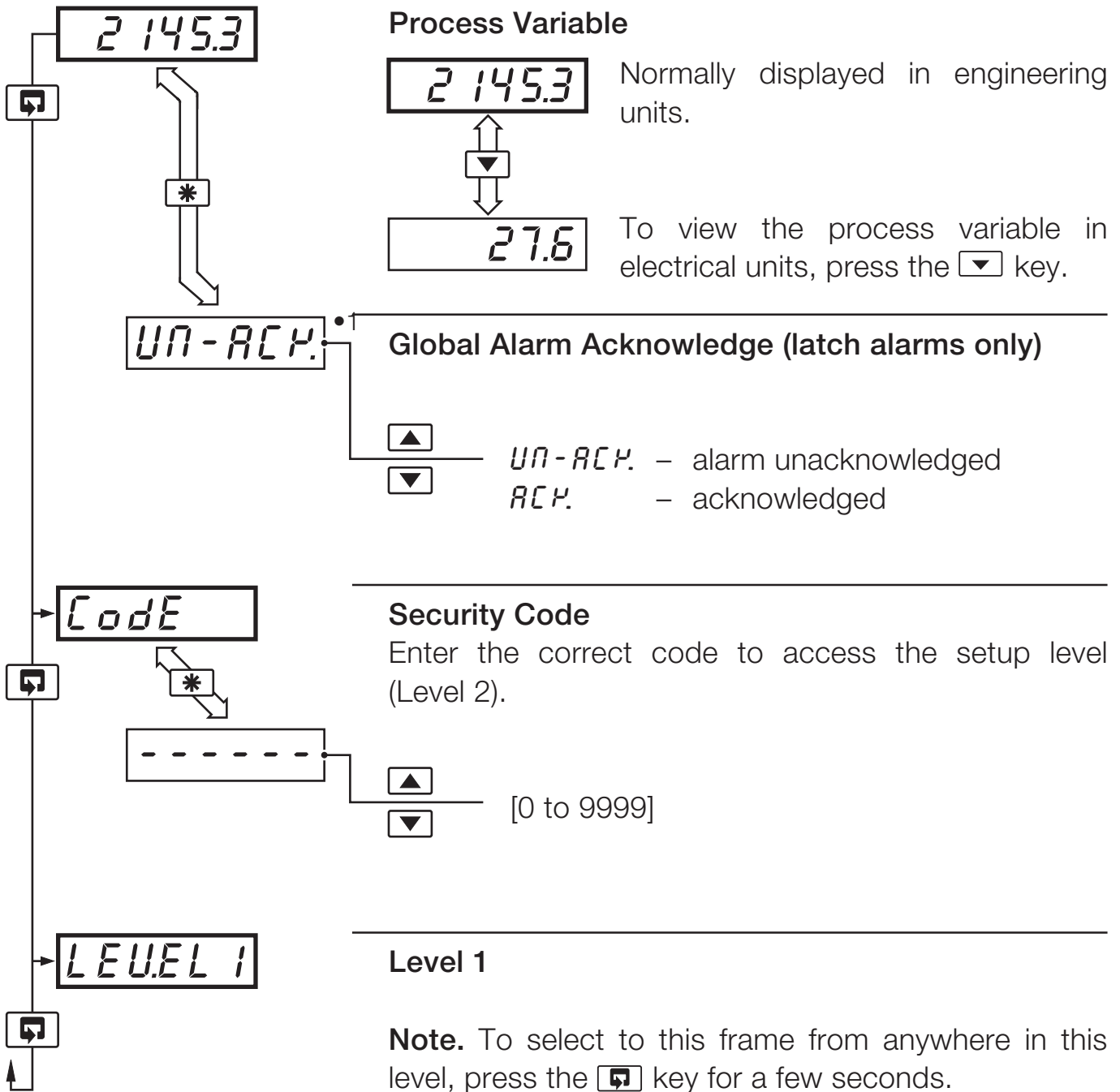

8 •1 Displayed only if there is an active latch alarm.



2.3 Operating Page – Totalizer (Level 1)

These frames are Displayed only if the totalizer function is enabled in the configuration level – see Section 4.3.3

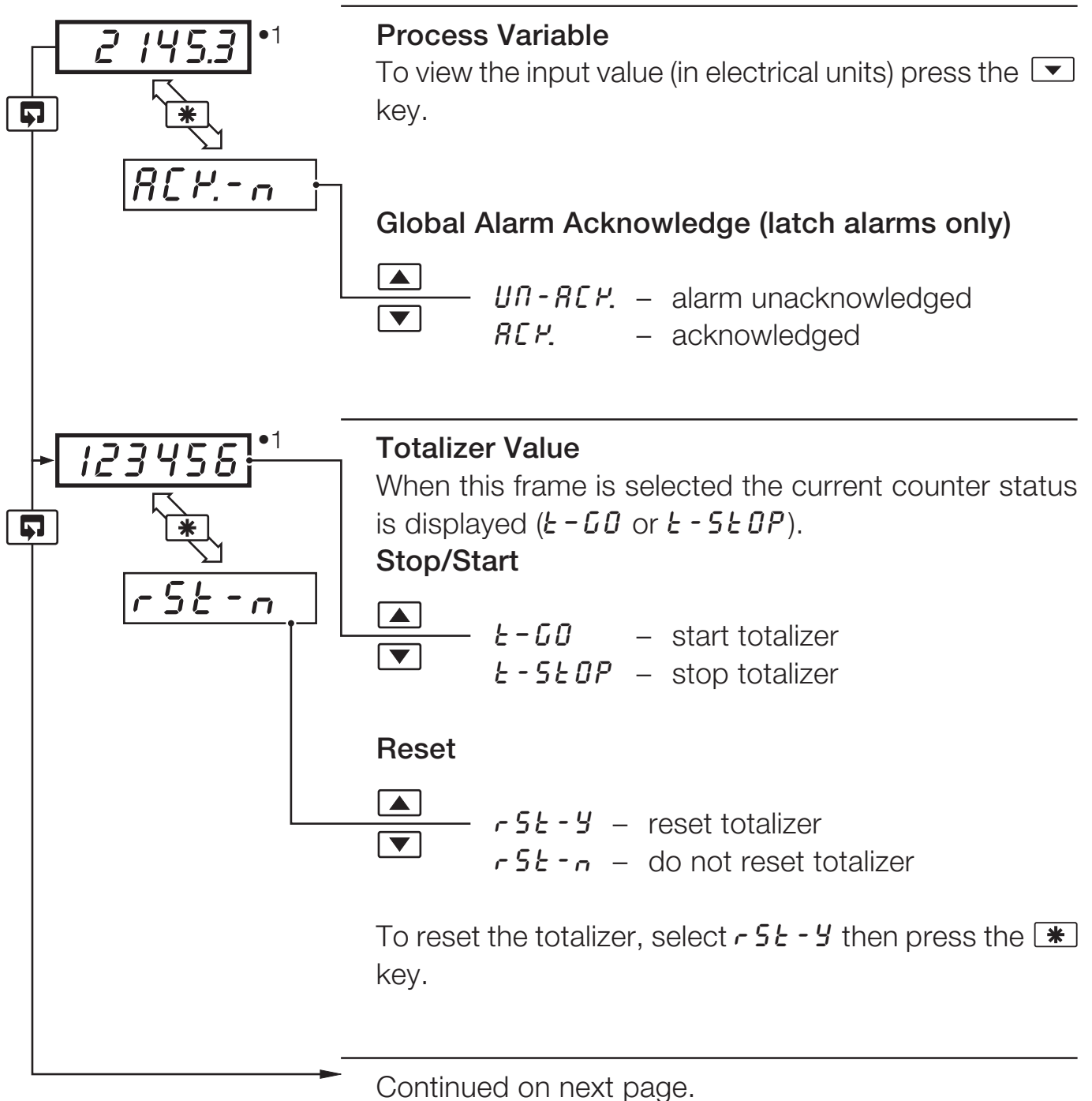

- 1 Totalizer stop/go and reset from these frames can be disabled – see Section 4.3.3.

A digital input can also be used to start/stop or reset the totalizer – see Section 4.3.4

...2.3 Operating Page – Totalizer (Level 1)

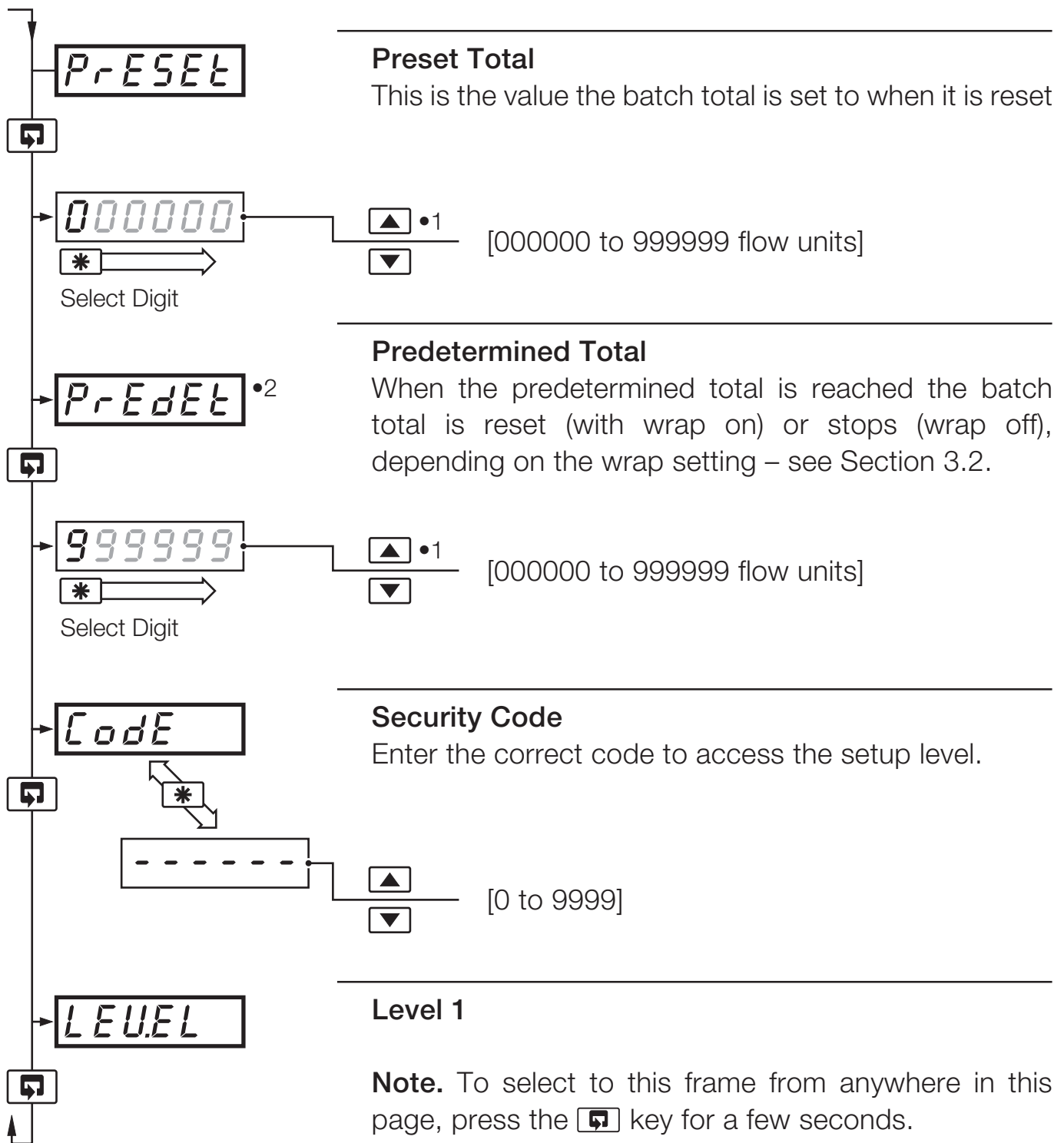

- 1 The predetermined value should be greater than the preset value when the totalizer is counting up and lower than the preset value when the totalizer is counting down.

10 •2 Displayed only if enabled in the configuration level – see Section 4.3.3.



2.4 Operating Page – Maths Functions (Level 1)

Note. It is possible to have totalizer and maths functions together.

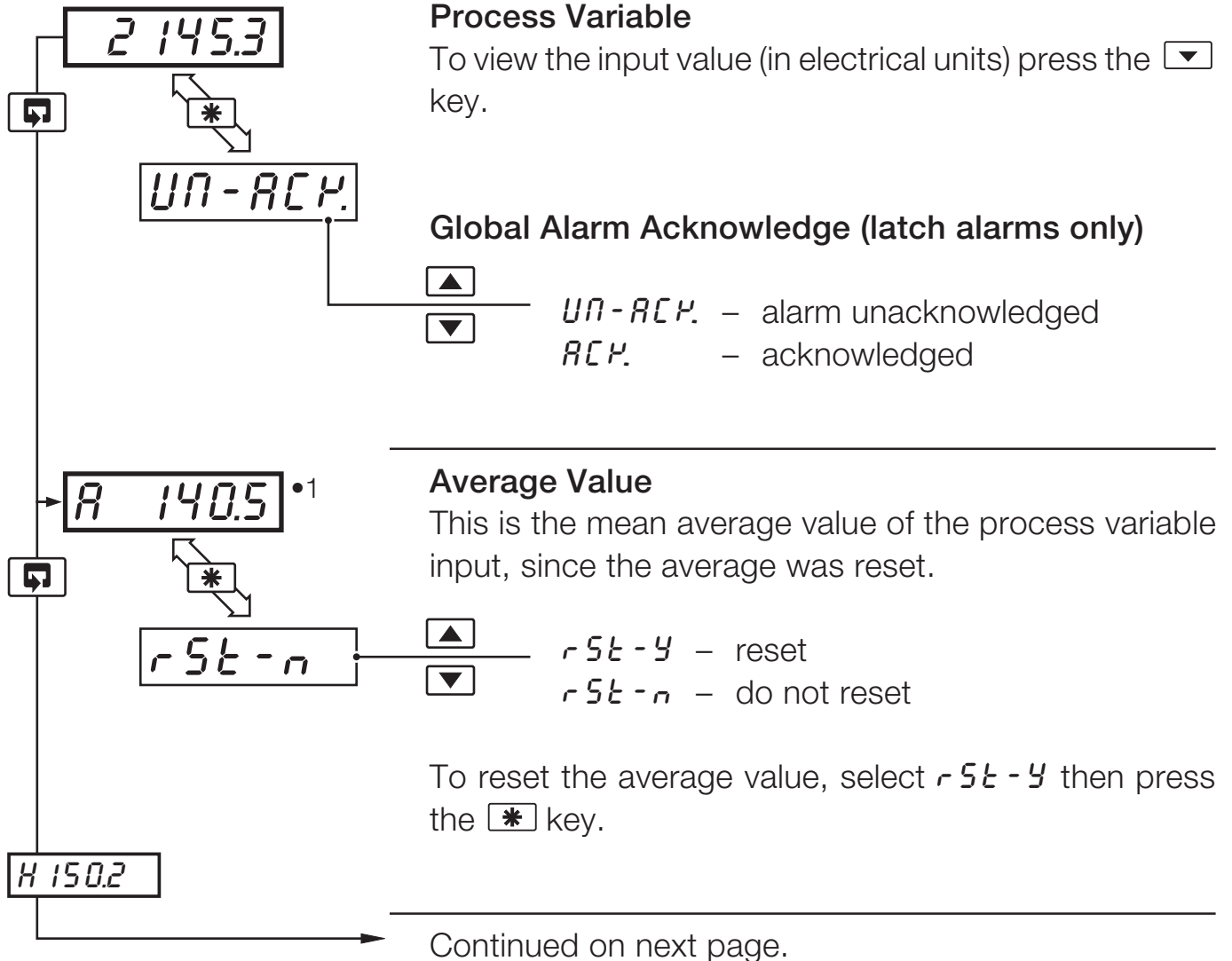

- 1 This frame can be disabled – see Section 4.3.3.

The average value is reset automatically on power-up and can also be reset from a digital input – see Section 4.3.4.

The reset function in this frame can be disabled – see Section 4.3.3.

...2.4 Operating Page – Maths Functions (Level 1)



Maximum Value

This is the maximum value of the process variable since the maximum was reset.

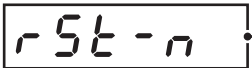

▲ *rSt-y* – reset

▼ *rSt-n* – do not reset

To reset the maximum value, select *rSt-y* then press the  key.



Minimum Value

This is the minimum value of the process variable since the minimum was reset.

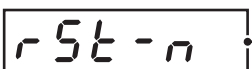

▲ *rSt-y* – reset

▼ *rSt-n* – do not reset

To reset the minimum value, select *rSt-y* then press the  key.



Security Code

Enter the correct code to access the setup level.



▲ [0 to 9999]

▼





Level 1

Note. To select to this frame from anywhere in this page, press the  key for a few seconds.

•1 This frame can be disabled – see Section 4.3.3.

The Max. and Min. values are reset automatically on power-up and can also be reset from a digital input – see Section 4.3.4.

12 The reset reset function in this frame can be disabled – see Section 4.3.3.

Tel: (01943) 602001- WWW.ISSLTD.CO.UK - Fax: (01943) 816796

3 SET UP MODE

3.1 Introduction

To access the Setup Level (Level 2) the correct password must be entered in the security code frame (CODE) in Level 1– see Fig. 3.1.

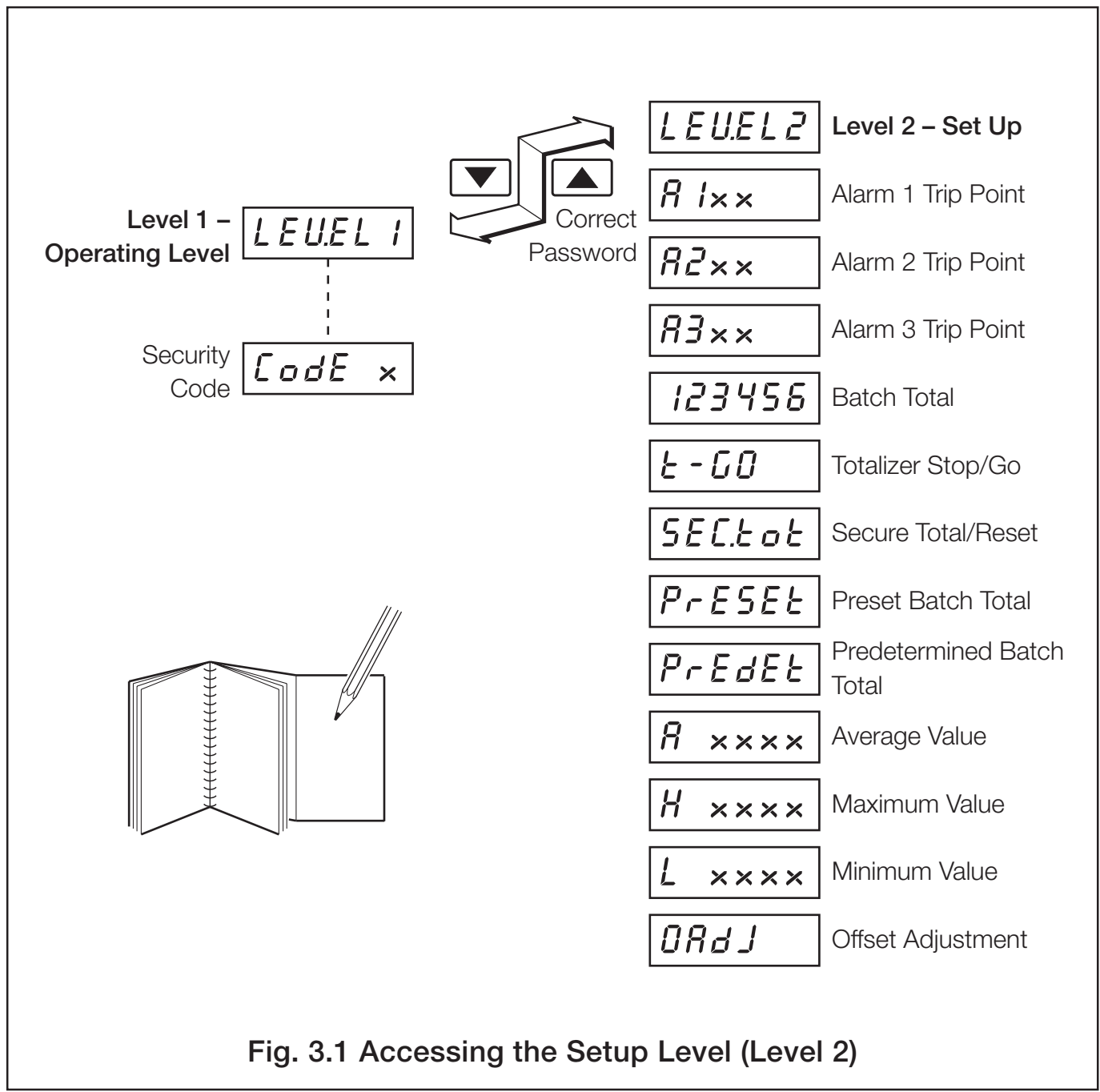
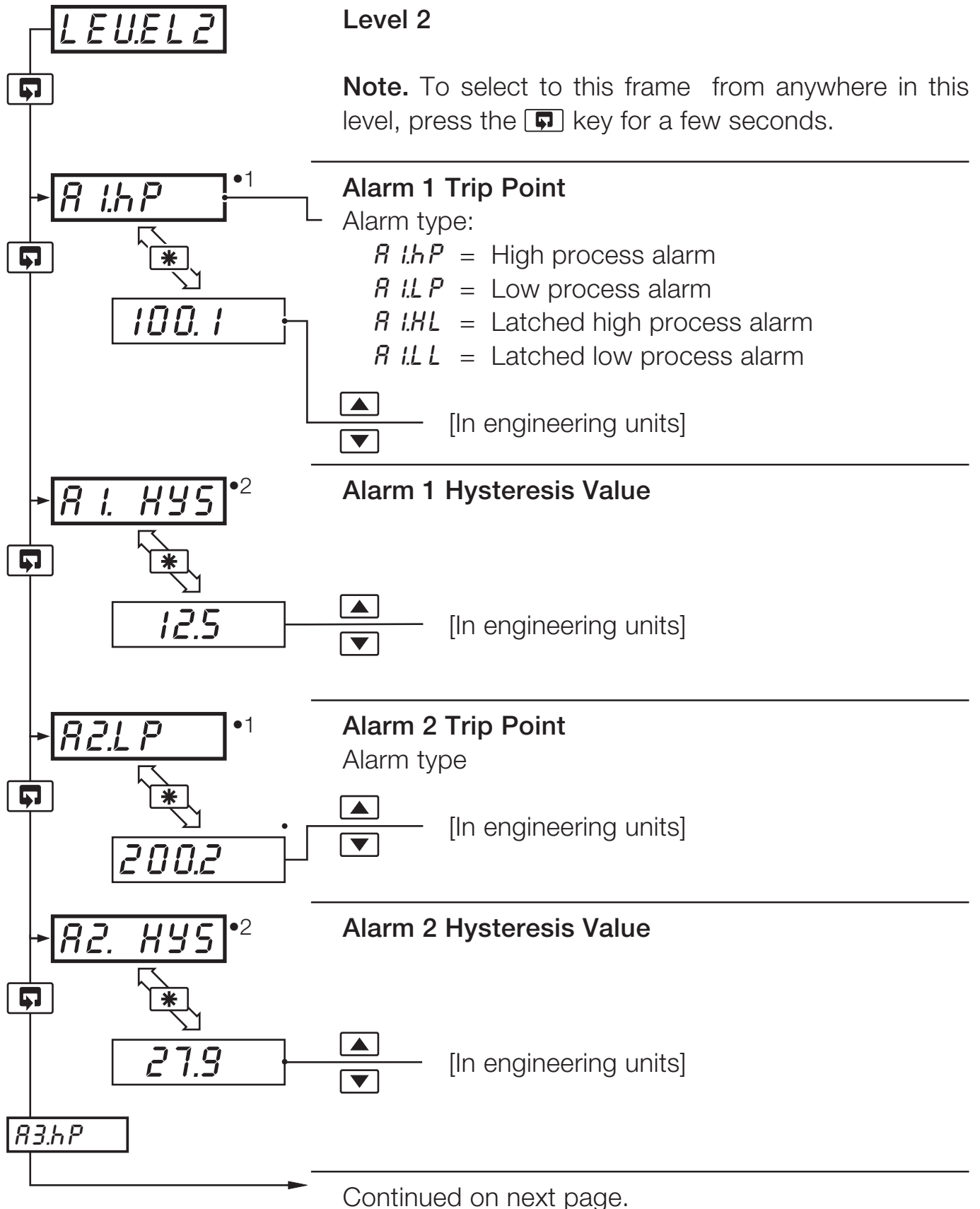

Fig. 3.1 Accessing the Setup Level (Level 2)

3.2 Setup Level (Level 2)



•1 Not displayed if the alarm is disabled (*None* selected) – see Section 4.3.2.

•2 Displayed only if custom alarm hysteresis is selected – see section 4.3.2



...3.2 Setup Level (Level 2)

A3.HP •1 **Alarm 3 Trip Point**
Alarm type
▲ [In engineering units]
▼

A3 HYS •2 **Alarm 3 Hysteresis Value**
▲ [In engineering units]
▼

123456 •3 **Totalizer Value**
▲ *rSt-y* – reset
▼ *rSt-n* – do not reset
•4

To reset the maximum value, select *rSt-y* then press the ***** key.

t-GO •3 **Totalizer Stop/Go**
▲ *t-GO* – start totalizer
▼ *t-STOP* – stop totalizer

Setting to *t-GO* starts the totalizer counting towards the predetermined value. Setting to *t-STOP* holds the totalizer at its present value.

SECT0t Continued on next page

- 1 Not displayed if the alarm is disabled (*None* selected) – see section 4.3.2
- 2 Displayed only if custom alarm hysteresis is selected – see section 4.3.2
- 3 Displayed only if enabled in the Configuration Level – see section 4.3.3
- 4 A digital input can also be used to reset the batch total.

...3.2 Set Up Level (Level 2)

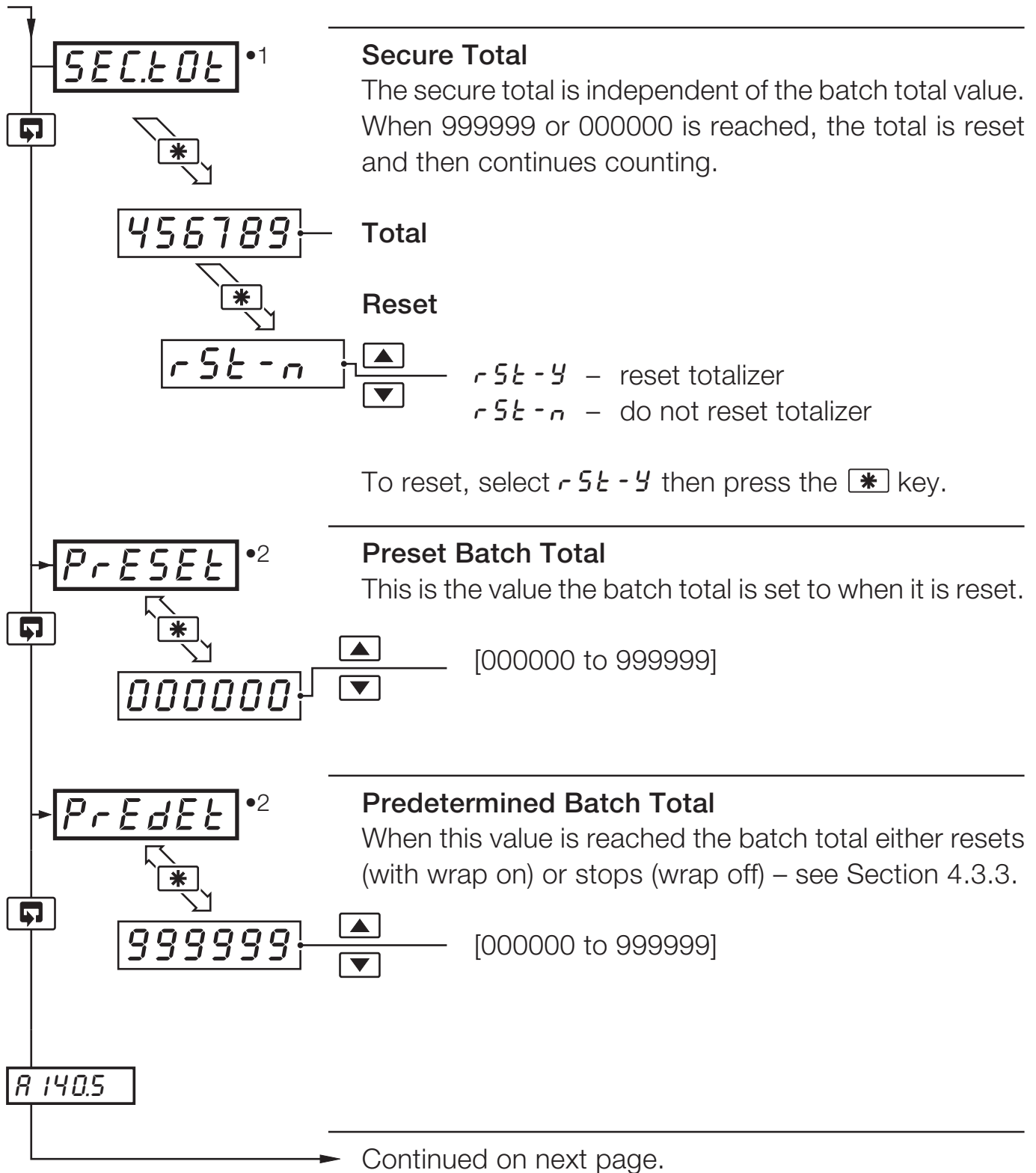

- ¹ Displayed only if enabled in the Configuration Level – see Section 4.3.3.
- ² The preset value must be lower than the predetermined value when counting up, and greater than the predetermined value when counting down.

...3.2 Set Up Level (Level 2)

Average Value
This is the mean average value of the process variable input since the average was reset.

Maximum Value
This is the maximum value of the process variable since the maximum was reset.

Minimum Value
This is the minimum value of the process variable since the minimum was reset.

Offset Adjustment
An offset can be applied to the process variable input to enable spot calibration or the removal of system errors.

To reset, select *rSt-y* then press the ***** key.

To reset, select *rSt-y* then press the ***** key.

To reset, select *rSt-y* then press the ***** key.

To reset, select *rSt-y* then press the ***** key.

[±10% of engineering range]

- 1 The average value is reset automatically on power-up and can also be reset from a digital input – see Section 4.3.4.
- 2 The maximum and minimum values are reset automatically on power-up and can also be reset from a digital input – see Section 4.3.4.



4 CONFIGURATION MODE

4.1 Introduction

The Configuration Mode comprises two levels (3 and 4) as shown in Fig. 4.2.

Configuration level 3 is divided into four frames. For most simple applications it is only necessary to set up the parameters in the first frame.

Note.

When in the Configuration Level:

- All the LED indicators flash.
- All relays and logic outputs are turned off.
- The analog output reverts to 0% (4mA) output level.

4.2 Accessing the Configuration Mode – Fig. 4.1

To access the Configuration Mode set the security switch to the 'Configure' position (levels 1 and 2 cannot be accessed from this setting). When the configuration parameters are programmed, reset the security switch to the 'Normal' position and the Operating page is displayed automatically .

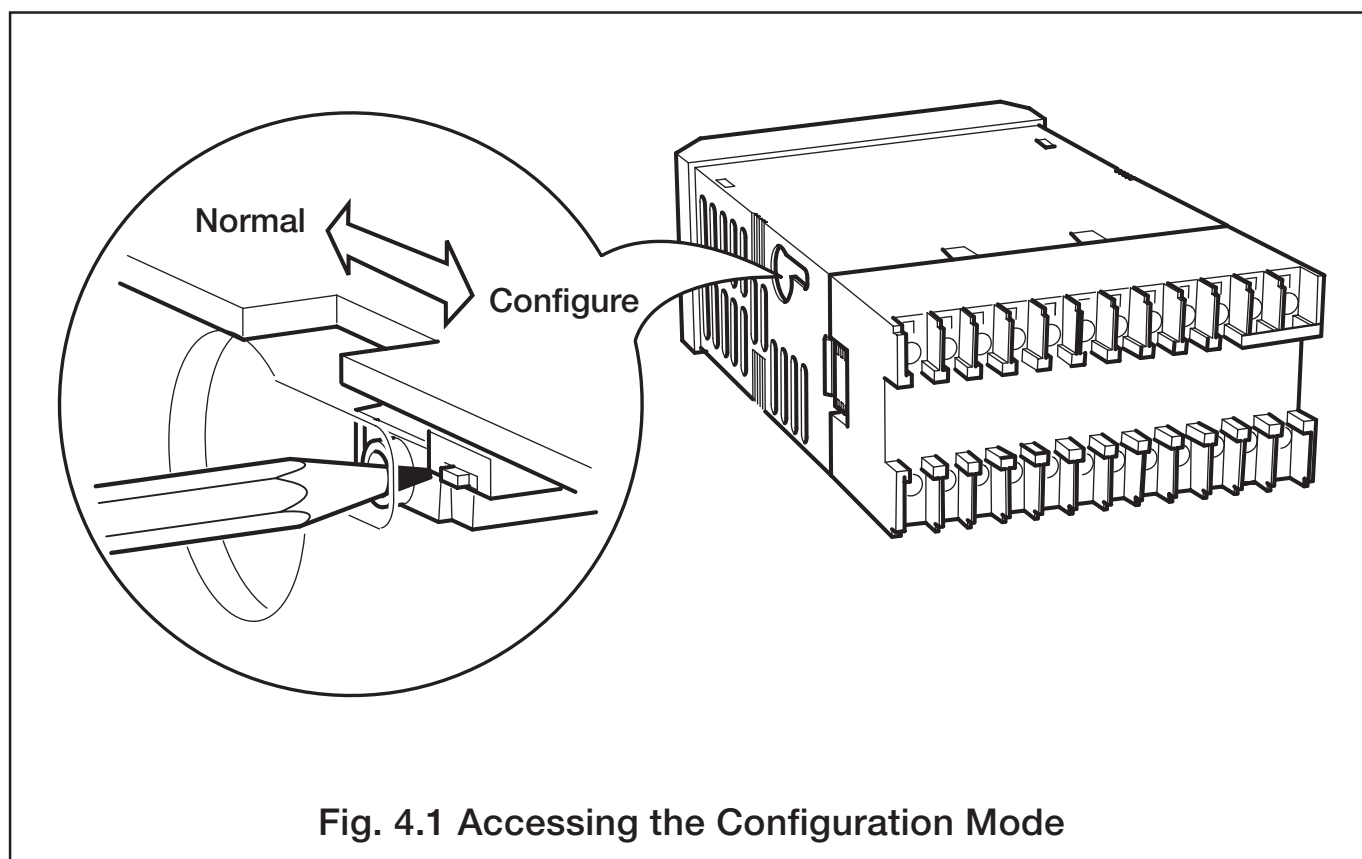

Fig. 4.1 Accessing the Configuration Mode

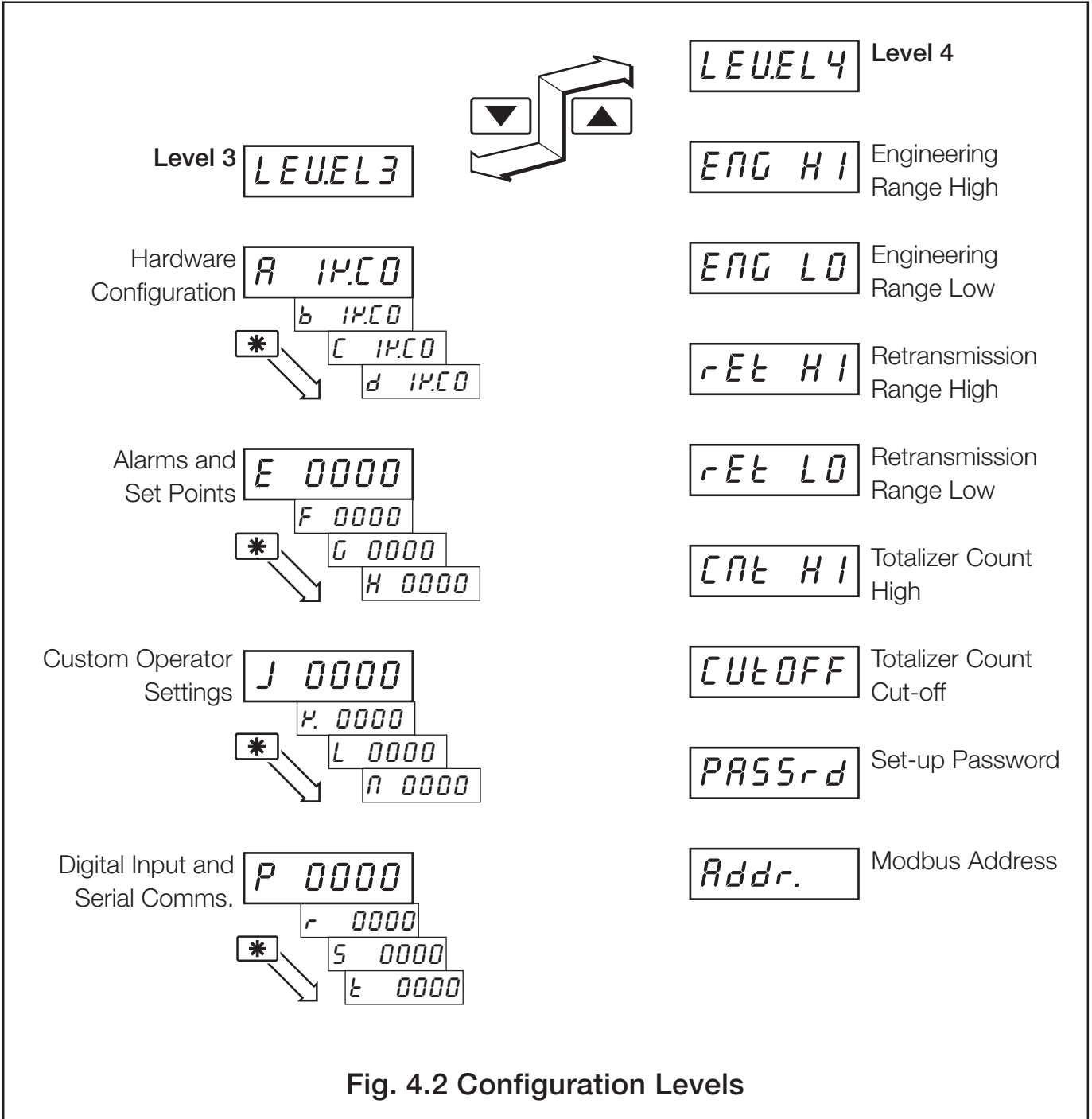

Fig. 4.2 Configuration Levels





4.3 Basic Hardware and Configuration (Level 3) – Fig. 4.3

4.3.1 Hardware Assignment and Input Type

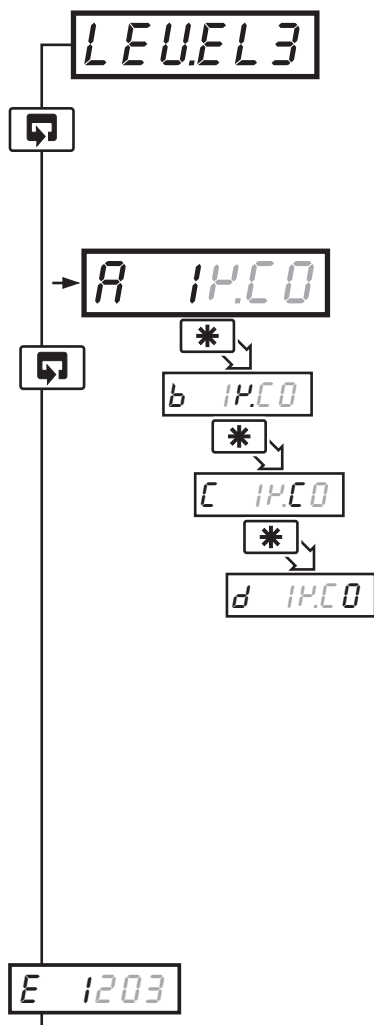

Level 3

Note. To select to this frame from anywhere in this level, press the  key for a few seconds.

'ABCD' Settings

The first character (*A*, *b*, *C* or *d*) identifies the parameter to be changed. The current setting is indicated by a flashing letter. Parameter options are shown in Fig. 4.3.

- A* = Hardware configuration
- b* = Input type and range
- C* = Temperature units
- d* = No. of decimal points

Note 1. The temperature ranges default to their maximum values when the input type is changed.

Note 2. For custom settings contact the local distributor.

Continued on page 22.

Note.

Count High Calculation:

$$\text{Convert flow rate into units/sec} = \frac{\text{actual engineering flow rate}}{\text{flow range time units (in seconds)}}$$

$$\text{Count High} = \frac{\text{units/sec}}{\text{counter factor}} \quad \text{resultant must be } >0.001 \text{ and } <99.999\text{pps.}$$

Counter factor is the engineering value of the least significant digit shown on the totalizer display – see Section 4.3.3.

Totalizer Count Pulse:

The totalizer count pulse is on for a preset time of 250ms and off for a minimum of 250ms.



A 14.C0 A – Hardware Configuration

50Hz/60Hz		Relay 1 Source	Relay 2* Source	Relay 3* Source	Logic O/P Source	Analog O/P Source
1	A	Alarm 1	Alarm 2	Alarm 3	TCP**	PV
2	b	Alarm 1	Alarm 2	Alarm 3	TWP**	PV
3	c	TCP**	Alarm 1	Alarm 2	TWP**	PV
4	d	TWP**	Alarm 1	Alarm 2	TCP**	PV
5	E	Alarm 1	Alarm 2	Alarm 3	TCP**	PV Average
U		Custom	Custom	Custom	Custom	Custom

TCP = Totalizer Count Pulse TWP = Totalizer Wrap Pulse PV = Process Variable

* Only available if the appropriate option board is fitted.

** Pulse energizes assigned relay

b 14.C0 B – Input Type and Range Configuration

Display		Display	
b	THC Type B	1	0 to 20 mA
E	THC Type E	2	4 to 20 mA
J	THC Type J	3	0 to 5 V
K	THC Type K	4	1 to 5 V
N	THC Type N	5	0 to 50 mV
R	THC Type R	7	4 to 20 mA (square root lineariser)
S	THC Type S	U	Custom Configuration
T	THC Type T		
P	PT100 RTD		

c 14.C0 C – Temperature Units

Display	Temperature Units
c	Degrees C*
F	Degrees F*
0	No temperature units

* Temperature inputs only

d 14.C0 D – Process Variable Display Decimal Places

Display	
0	xxxx
1	xxx . x
2	xx . xx
3	x . xxx
4	x . xxxx

Fig. 4.3 Hardware Configuration and Input/Output Ranges





4.3.2 Alarms – Figs. 4.4 and 4.5

Note. Relays assigned to alarms are de-energized in the alarm state.

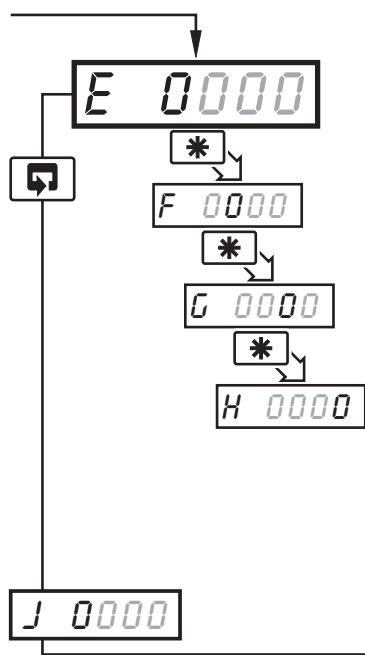

'EFGH' Settings

The first character (*E*, *F*, *G* or *H*) identifies the parameter to be changed. The current setting is indicated by a flashing letter. Parameter options are shown in Fig. 4.5.

- E* = Alarm 1 type
- F* = Alarm 2 type
- G* = Alarm 3 type
- H* = Alarm hysteresis

Note. For custom settings contact the local distributor.

Continued on page 24.

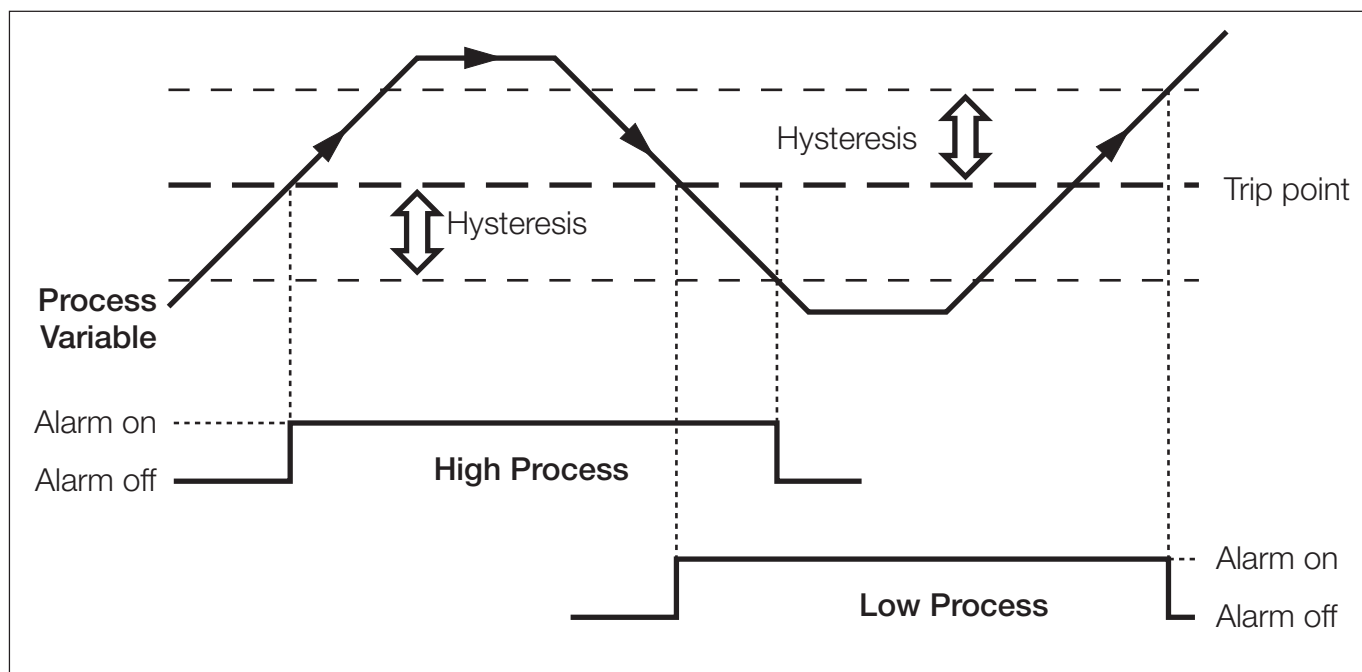

Note. For latch alarms the relay remains de-energized until acknowledged in Level 1 (or by a digital input).

Fig. 4.4 Alarm Action





E 0000 E – Alarm 1 Type

Display	
0	None
1	High Process
2	Low Process
3	High Latch
4	Low Latch

F 0000 F – Alarm 2 Type

Display	
0	None
1	High Process
2	Low Process
3	High Latch
4	Low Latch

G 0000 G – Alarm 3 Type

Display	
0	None
1	High Process
2	Low Process
3	High Latch
4	Low Latch

h 0000 H – Alarm Hysteresis

Display	
0	None
1	0.1%
2	0.2%
3	0.5%
4	1.0%
5	2.0%
6	5.0%
U	Custom

} Value in % of engineering range

} Value in engineering units – see Note

Note. When custom alarm hysteresis is selected, the alarm hysteresis values are set individually in the Set Up Level – See section 3.2.

Fig. 4.5 Alarm Setup





4.3.3 Operator Functions and Totalizer Set Up – Fig. 4.6

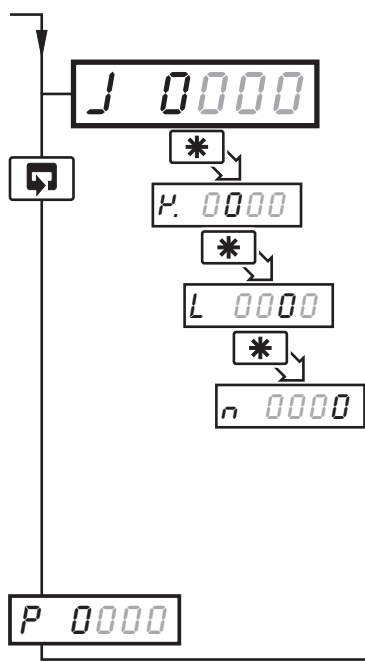

'JKLN' Settings

The first character (*J*, *P*, *L* or *n*) identifies the parameter to be changed. The current setting is indicated by a flashing letter. Parameter options are shown in Fig. 4.6.

- J* = Totalizer set-up
- P* = No. of decimal places for totalizer
- L* = Operator level frame enable
- n* = Operator level functions enable/disable

Note. For custom settings contact the local distributor.

Continued on page 26.





J 0000 J – Totalizer Setup

Display	
0	Off
1	Count Up, Wrap Off
2	Count Up, Wrap On
3	Count Down, Wrap Off
4	Count Down, Wrap On

P. 0000 K – Totalizer Display Decimal Places

Display	
0	xxxxxx
1	xxxxx.x
2	xxxx.xx
3	xxx.xxx
4	xx.xxxx
5	x.xxxxx

L 0000 L – Operator Level Frame Enable

Display	Max/Min Values Displayed	Average Value Displayed	Preset/Predetermined Values Displayed
0	No	No	No
1	Yes	No	No
2	Yes	Yes	No
3	No	Yes	Yes
4	No	No	Yes
5	Yes	No	Yes
6	Yes	Yes	Yes

This frame determines which frames appear in the operating page (level 1)

n 0000 N – Operator Level Math Function & Totalizer Control Enable

Display	Totalizer Stop/Go	Totalizer Reset	Max./Min./Average
0	No	No	No
1	Yes	No	No
2	No	Yes	No
3	Yes	No	Yes
4	No	Yes	Yes
5	Yes	Yes	Yes

This frame determines which functions the operator can control

Fig. 4.6 Totalizer Setup and Operator Functions





4.3.4 Digital Input and Serial Communications – Figs. 4.7 and 4.8

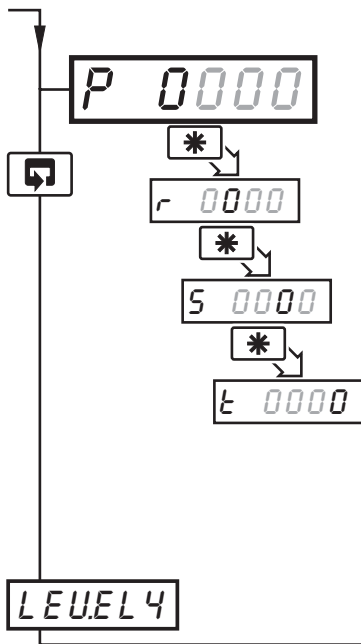

'PRST' Settings

The first character (*P*, *r*, *S* or *t*) identifies the parameter to be changed and the current setting is indicated by a flashing letter. Parameter options are shown in Fig. 4.8.

- P* = Digital input function
- r* = Analog input filter
- S* = Serial communications configuration
- t* = Serial communications parity

Note. For custom settings contact the local distributor.

Continued on page 28.



1 Totalizer Reset

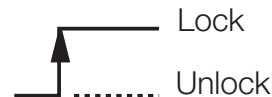

4 Front Panel Lock out



2 Totalizer Stop/Go



5 Alarm Acknowledge

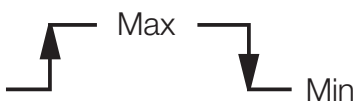

3 Average Max/Min Reset

Note. Digital input options 1, 2, 3 and 5 are edge-triggered to enable the front panel keys to change the function when the digital input is operational.

Fig. 4.7 Digital Function Configuration





P 0000 P – Digital Input Function

Display	
0	None
1	Totalizer Reset
2	Totalizer Stop/Go
3	Average, Max/Min Reset
4	Front Panel Lockout
5	Alarm Acknowledge

r 0000 R – Analog Input Filter

Display	
0	0 seconds
1	1 second
2	2 seconds
5	5 seconds
R	10 seconds
b	20 seconds
c	40 seconds
d	60 seconds

S 0000 S – Serial Communication Configuration

Display	Baud Rate, 2/4 Wire
0	Off
1	2400, 2 Wire
2	2400, 4 Wire
3	9600, 2 Wire
4	9600, 4 Wire

t 0000 T – Serial Communication Parity

Display	
0	None
1	Odd
2	Even

Note. Settings for options P, S and T are available only if the appropriate option board is fitted.

Fig. 4.8 Digital Function and Serial Communications Configuration





4.4 Ranges and Passwords (Level 4)

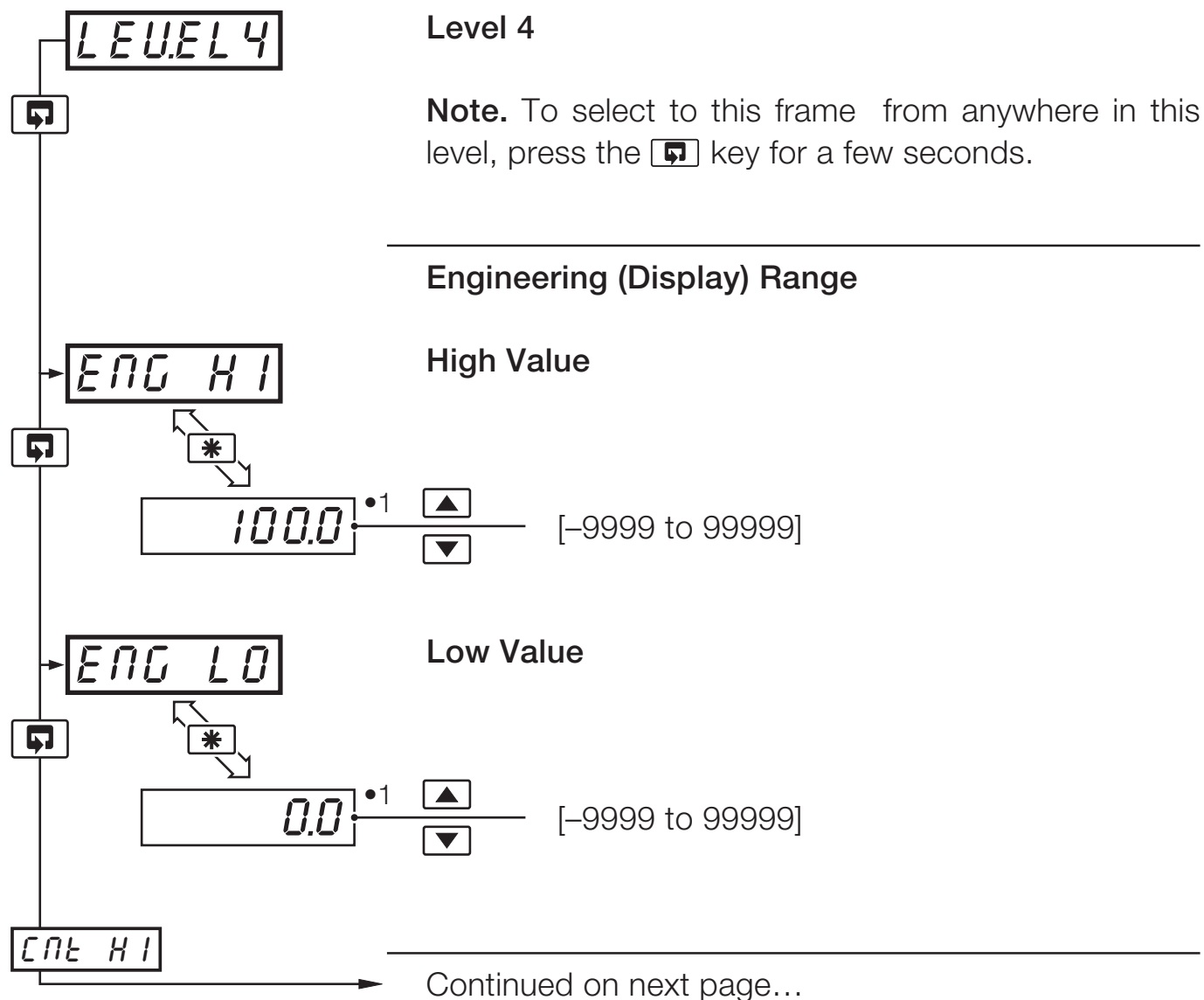

- 1 The engineering range high and low values are automatically set to the maximum allowed value when thermocouple or RTD is selected in the configuration level – see Section 4.3.1. This value can be modified if required.





...4.4 Ranges and Passwords (Level 4)

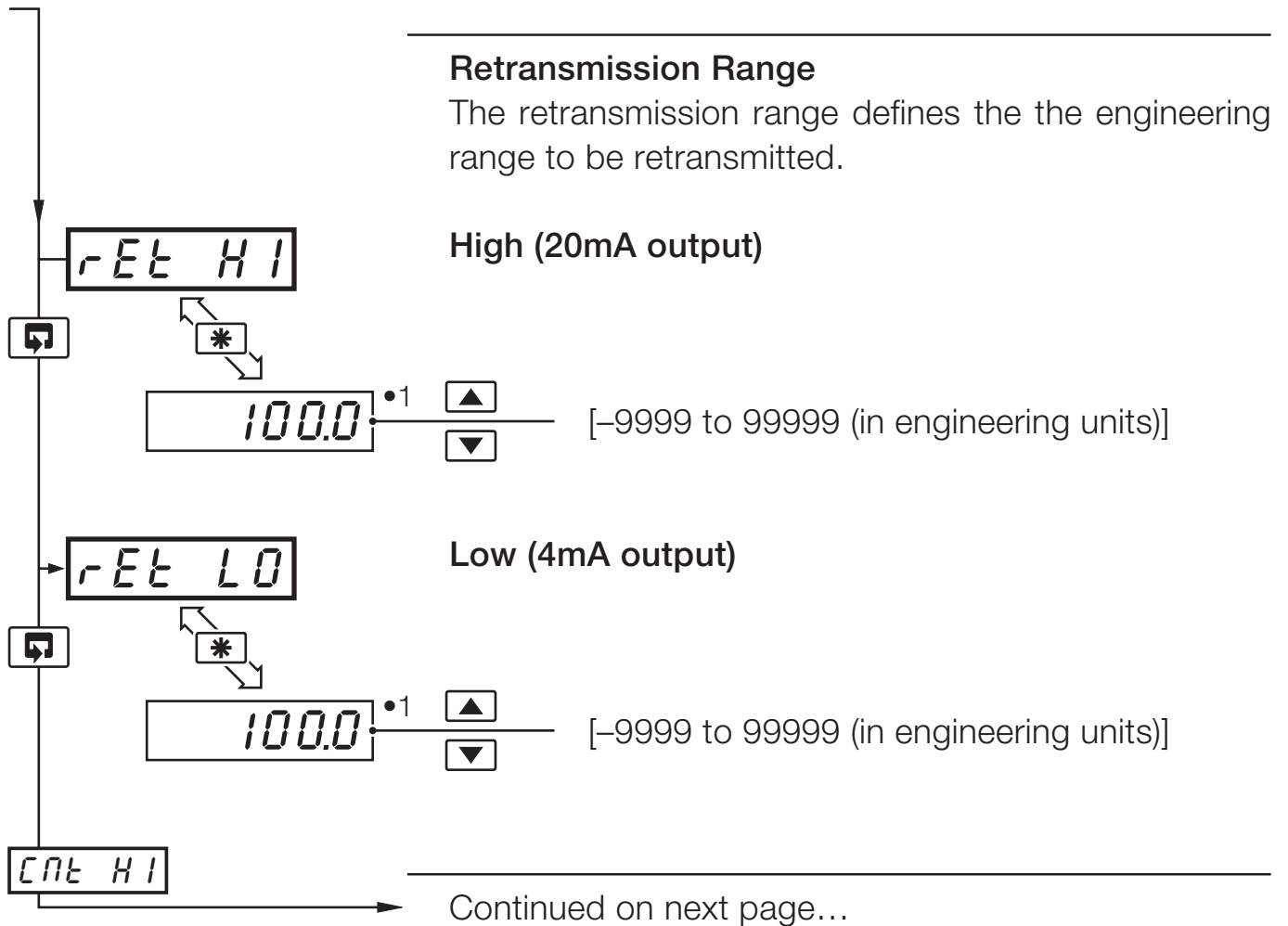

- 1 The retransmission range high and low values are automatically set to the maximum allowed value when thermocouple or RTD is selected in the configuration level – see Section 4.3.1. This value can be modified if required. 29





...4.4 Ranges and Passwords (Level 4)

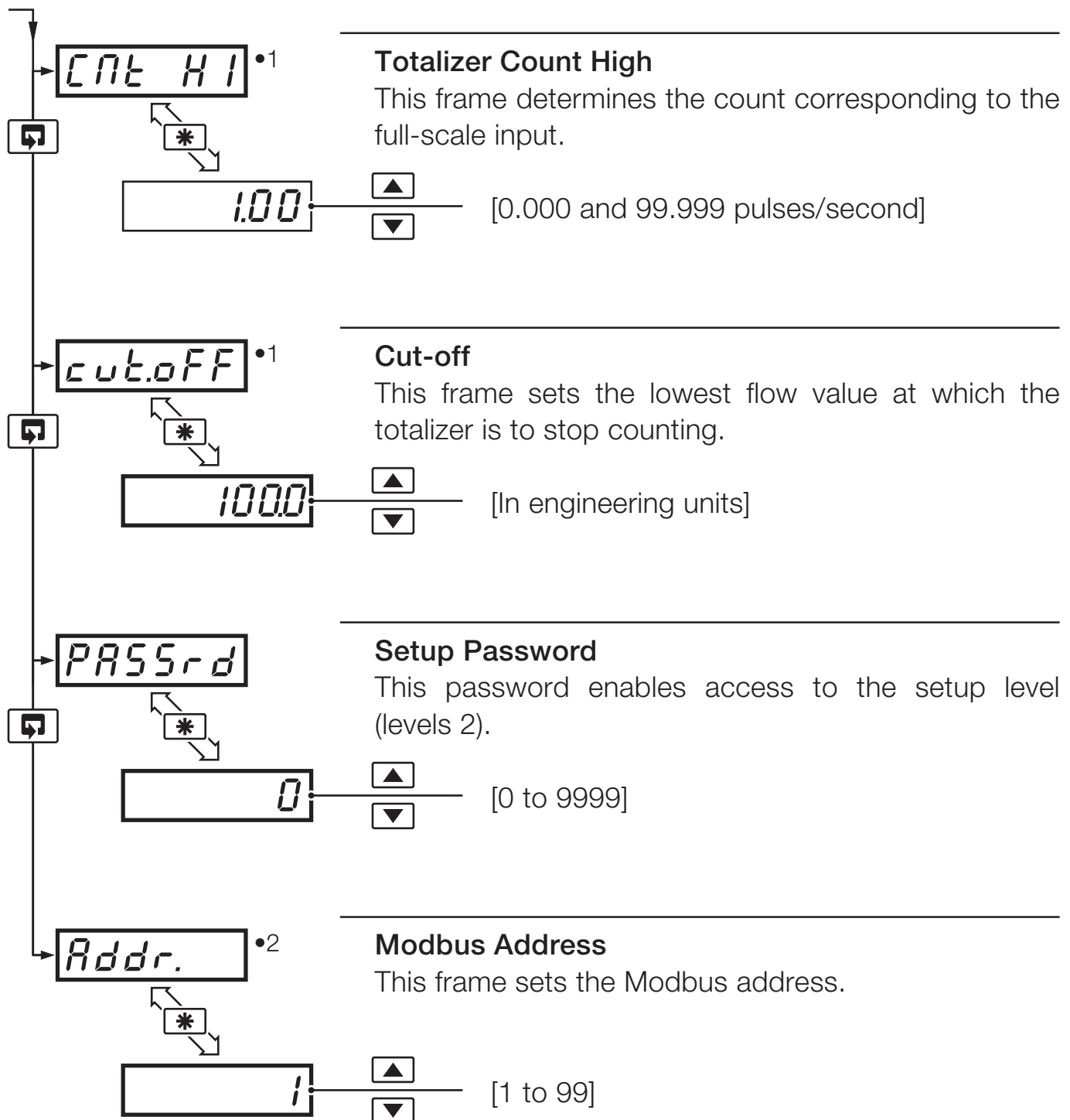

•1 Displayed only if enabled in the configuration level – see Section 4.3.3.

30 •2 Available only if the appropriate option board is fitted.





5 INSTALLATION

EC Directive 89/336/EEC

In order to meet the requirements of the EC Directive 89/336/EEC for EMC regulations, this product must not be used in a non-industrial environment.

End of Life Disposal

This instrument does not contain any substance that will cause undue harm to the environment. It can therefore be safely considered as normal waste and disposed of accordingly.

Cleaning

Clean the front panel only, using warm water and a mild detergent.





5.1 Siting – Figs. 5.1 and 5.2

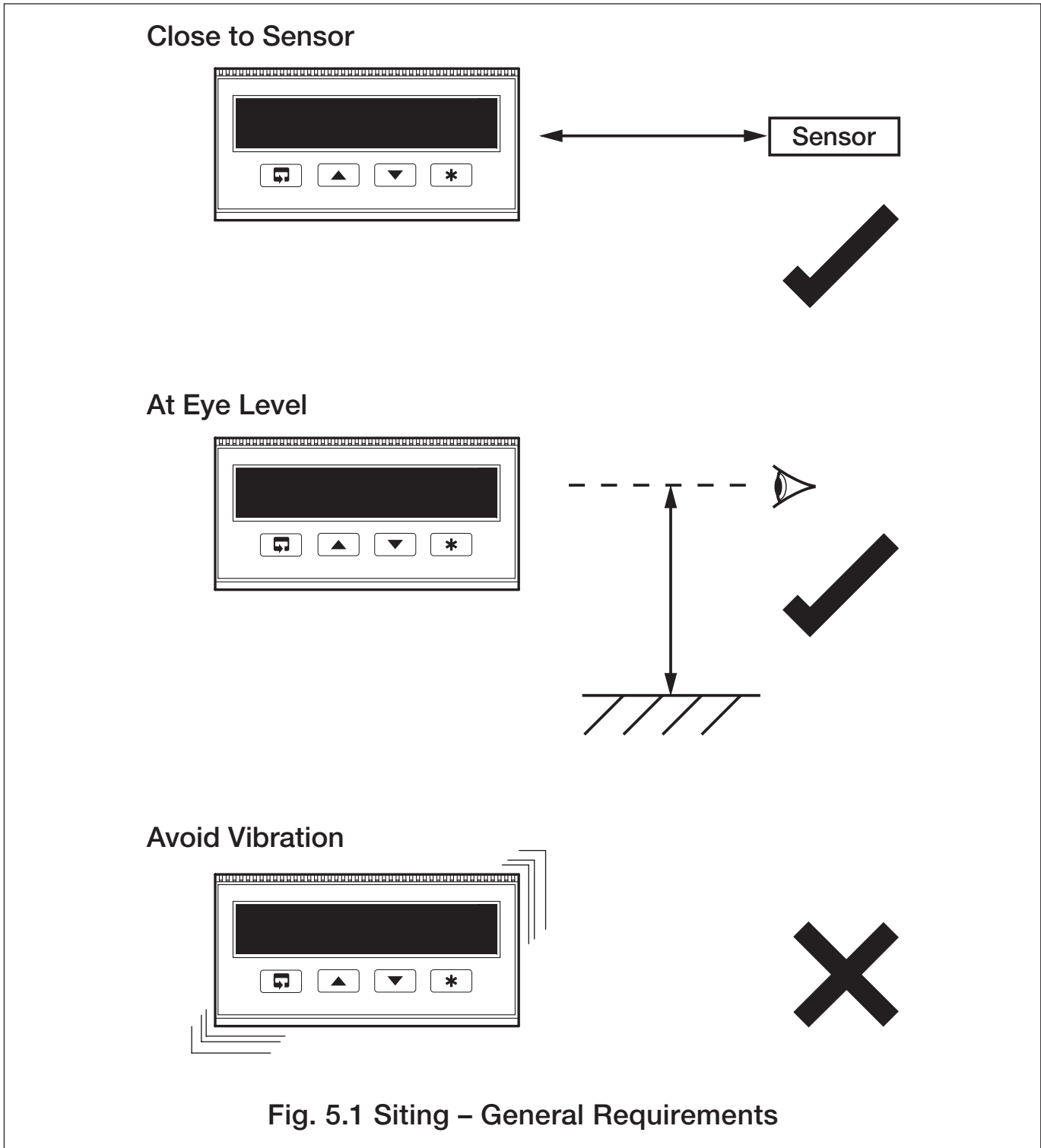



...5.1 Siting – Figs. 5.1 and 5.2

Temperature Limits

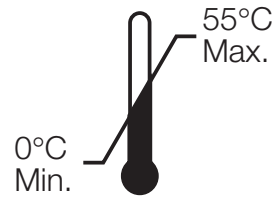
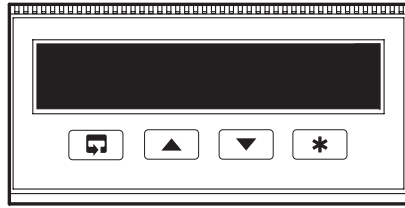

Humidity Limits

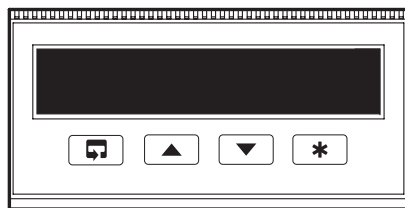

0 to 90% RH

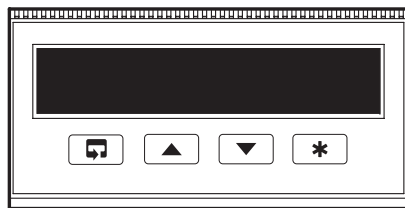

Environmental Limits

IP65/NEMA3
(front panel)IP20
(rear)

Use Screened Cable

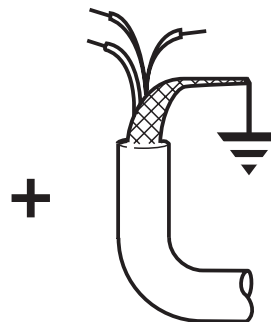
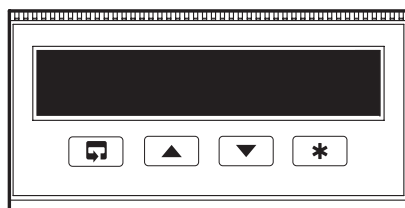

Warning. Select a location away from strong electrical and magnetic fields. If this is not possible, particularly in applications where mobile communications equipment is expected to be used, screened cables within earthed metal conduit must be used.

Fig. 5.2 Environmental Requirements

5.2 Mounting – Figs. 5.3 and 5.4

The instrument is designed for panel mounting (see Fig. 5.4). Overall dimensions are shown in Fig. 5.3.

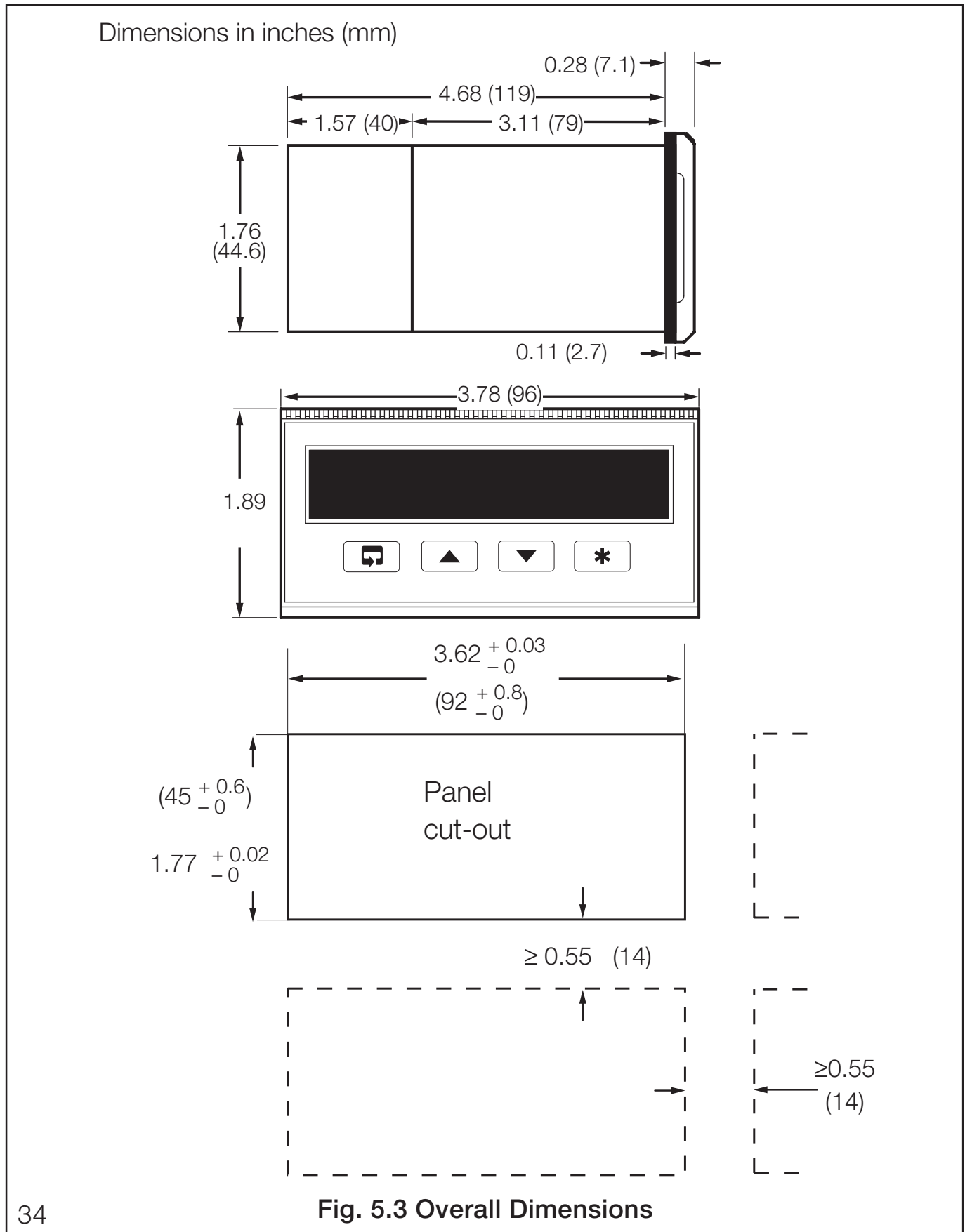



...5.2 Mounting – Figs. 5.3 and 5.4

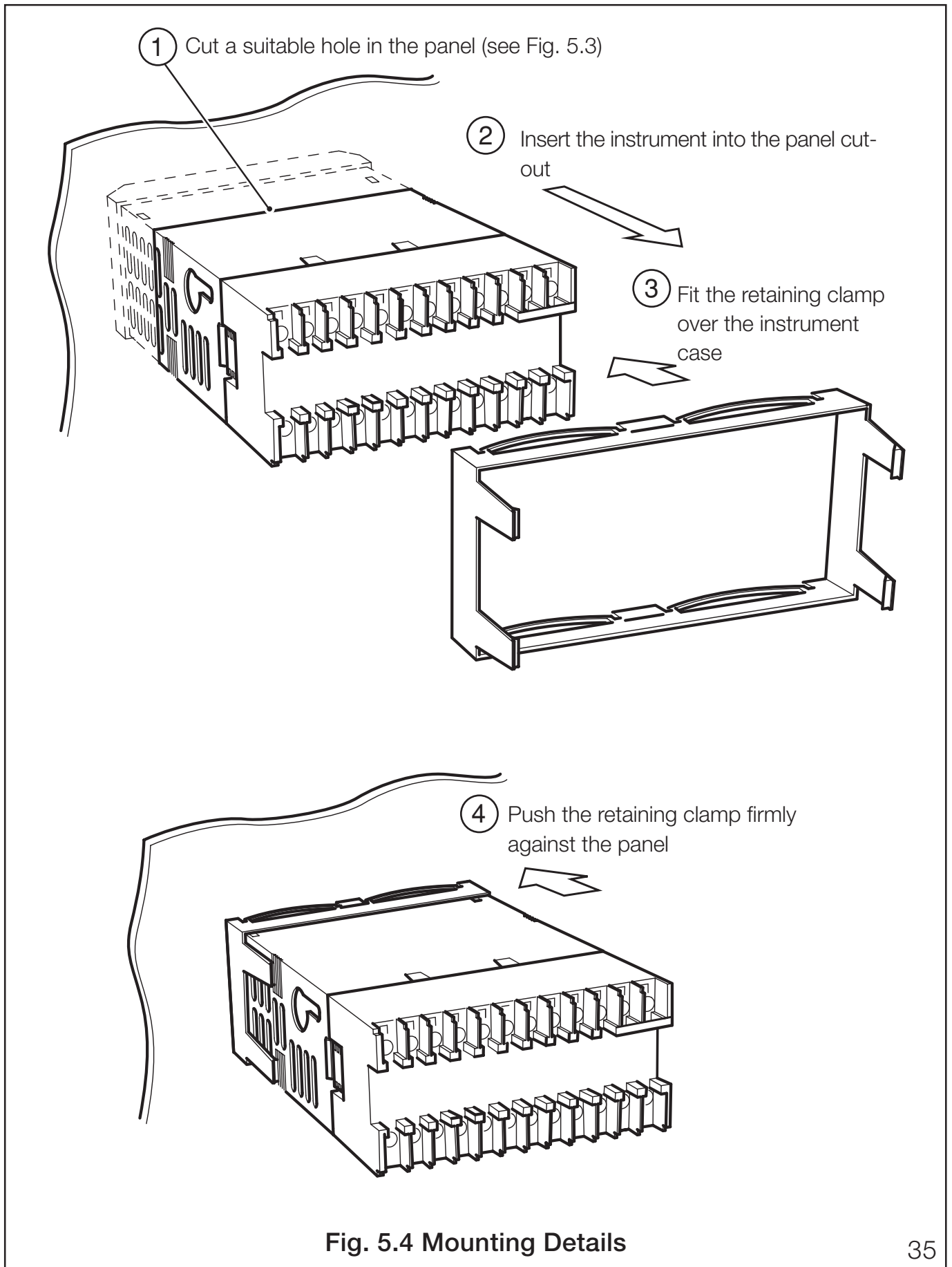

Fig. 5.4 Mounting Details

5.3 Electrical Connections – Fig. 5.5



Warning.

- The instrument is not fitted with a switch therefore a disconnecting device such as a switch or circuit breaker conforming to local safety standards must be fitted to the final installation. It must be mounted in close proximity to the instrument within easy reach of the operator and must be marked clearly as the disconnection device for the instrument
 - Remove all power from supply, relay and any powered control circuits and high common mode voltages before accessing or making any connections.
 - Use cable appropriate for the load currents. The terminals accept cables up to 14AWG (2.5mm²).
 - The instrument conforms to Mains Power Input Insulation Category 2, Pollution Degree 2 (EN601010–1).
 - All connections to secondary circuits must have basic insulation.
 - After installation, there must be no access to live parts, e.g. terminals
 - Terminals for external circuits are for use only with equipment with no accessible live parts.
 - If the instrument is used in a manner not specified by the Company, the protection provided by the equipment may be impaired.
 - All equipment connected to the instrument's terminals must comply with local safety standards (IEC 60950, EN601010–1).
-

Note.

- Always route signal leads and power cables separately, preferably in earthed (grounded) metal conduit.
 - It is strongly recommended that screened cable is used for signal inputs and relay connections.
-



This equipment is protected through double insulation (Class II).

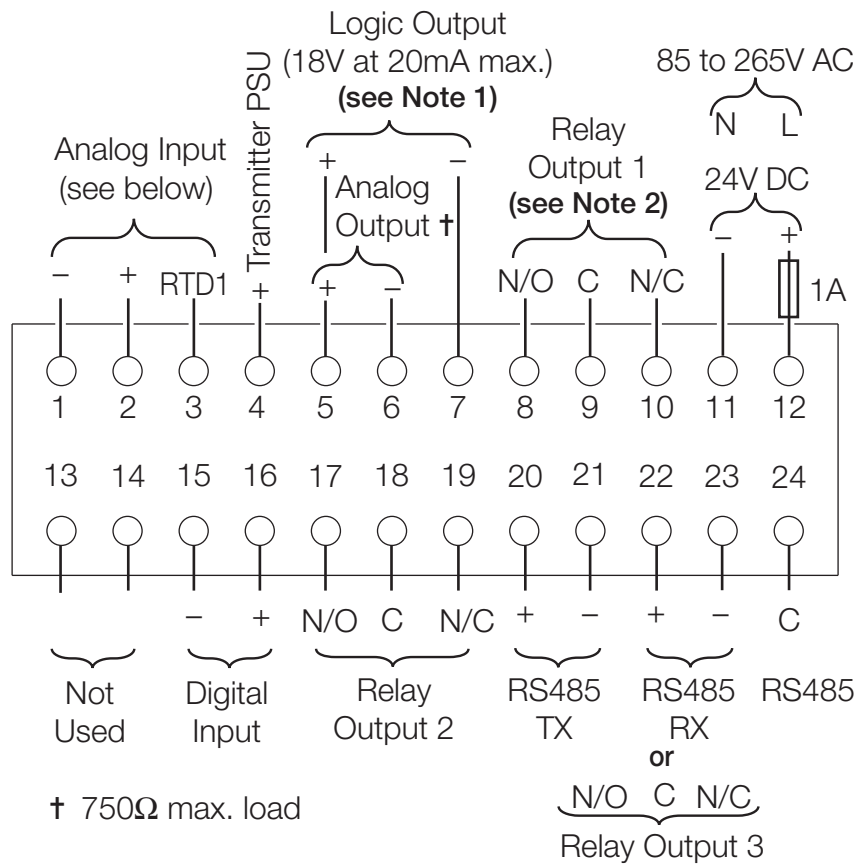

Notes

1. The Analog Output and Logic Output use a common positive terminal, capable of driving both outputs simultaneously.
2. Fit arc suppression components if switching inductive loads.

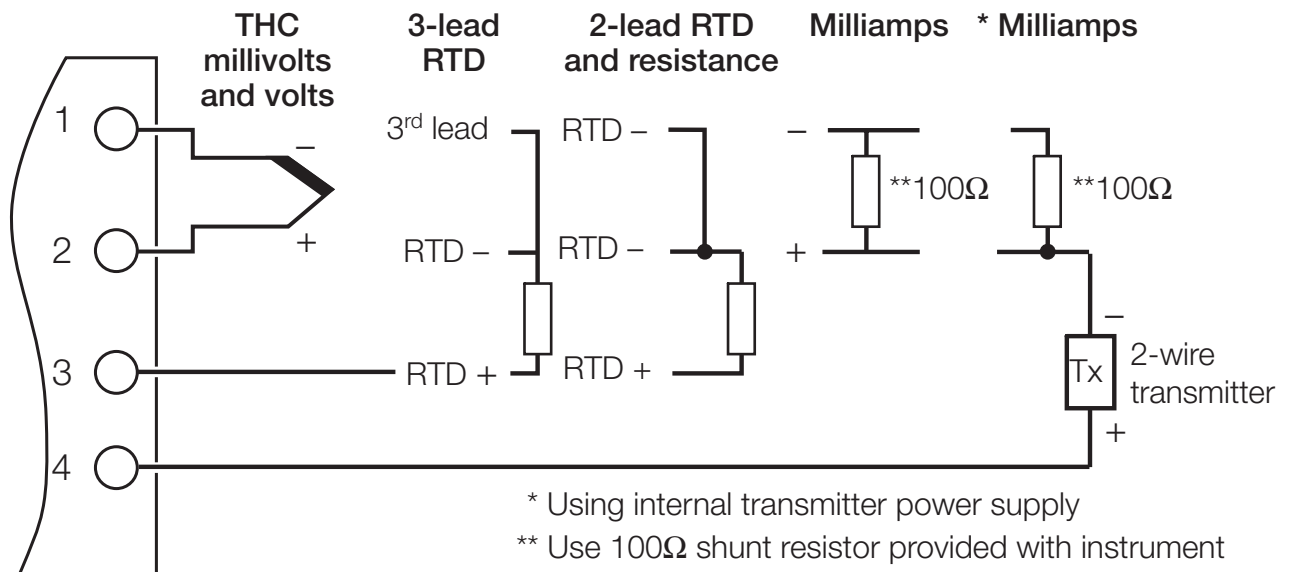

Fig. 5.5 Electrical Connections



5.4 Relays, Arc Suppression, Inputs and Outputs

5.4.1 Relay Contact Ratings

Relay contacts are rated at:

115/230V AC at 5A (non-inductive)

250V DC 25W max.

5.4.2 Arc Suppression

Arc suppression components are fitted to relays 2 and 3 only. If relay 1 is required to switch inductive loads, fit the arc suppression components supplied.

5.4.3 Logic Output

18V DC at 20mA

Min load 900Ω

Isolated from Analog Input (not isolated from Retransmission O/P).

Dielectric strength: 500V d.c. for 1 minute.

5.4.4 Retransmission

Analog Output

Max. load 15V (750Ω at 20mA)

Isolated from Analog Input (not isolated from Logic O/P).

Dielectric strength: 500V d.c. for 1 minute.

5.4.5 Digital Input

Type: Volt-free

Minimum Pulse: 250 ms

SPECIFICATION

Summary

- Fully user-configurable
- Hoseproof front face
- Large six-digit display
- Totalizer/math functions as standard

Operation

Display

- High-intensity 7-segment, 1 x 6-digit LED display
- Three alarm LED indicators
 - Display range -9999 to +99999
 - Display resolution ±1 digit
 - Display height 14mm (0.56inches)

Configuration

- User-defined via front panel and internal links.

Standard Functions

Totalizer

- Six-digit, batch and secure totals

Alarms

- Number Three user-defined
- Types High/low process
 High/low latch

Math function

- Maximum and minimum value detection
- Average value calculation



...SPECIFICATION

Analog Inputs

Number

One as standard

Input sampling rate

250ms per channel

Type

Universally configurable to provide:

Thermocouple (THC)

Resistance Thermometer (RTD)

Millivolt

Current

DC Voltage

Input Impedance

mA 100 Ω

mV, V >10M Ω

Linearizer functions

Programmable for:

SqRoot, THC types B, E, J, K, N, R, S, T or Pt100

Broken sensor protection

Upscale drive on thermocouple and RTD

Downscale drive on milliamps and voltage

Cold junction compensation

Automatic CJC incorporated as standard

Stability <0.05 $^{\circ}$ C/ $^{\circ}$ C change in ambient temperature

Input protection

Common mode isolation >120dB at 50/60Hz with 300 Ω imbalance resistance

Series mode rejection >60db at 50/60Hz

Transmitter power supply

24V, 30mA max. powers one 2-wire transmitter

Standard Analog Input Ranges

Outputs

Retransmission

Analog, configurable in the range of 4 to 20mA

Max. load 15V (750 Ω at 20mA)

Accuracy $\leq 0.25\%$ of span

Dielectric 500V DC from I/P (not isolated from logic O/P)

Assignable to Process Variable or Average PV

Logic output

18V DC at 20mA

Min. load 400 Ω

Isolation 500V from I/P (not isolated from retransmission O/P)

Relay output

One relay as standard (SPDT) 5A at 115/230V AC

Assignable to alarms, totalizer count pulse, totalizer wrap pulse or end of batch alarm.

Options

One option board can be installed from:

Type 1 One relay

Type 2 Two relays + one digital I/P

Type 3 One relay + one digital I/P + Modbus serial communications

Relay output

SPDT 5A at 115/230V AC

Assignable to alarms

Digital input

Type Volt-free

Minimum pulse 250ms

Modbus serial communications

Connections RS422/RS485, 2 or 4-wire

Speed 2.4k or 9.6k baud rate

Protocol Modbus RTU slave



...SPECIFICATION

Physical

Size

96mm wide x 48mm high x 125mm depth
(3.78 in. wide x 1.89 in. high x 4.92 in. depth)

Weight

250g (0.5lb) approximate

Electrical

Voltage

85V min. to 265V max. AC 50/60Hz
(24V DC option)

Power consumption

<6VA

Power interruption protection

<60ms/< 3 cycles, no effect

>60ms/>3 cycles, instrument returns to operation after a controlled reset



Environmental

Operating limits

0 to 55°C (32 to 131°F)

5 to 95% RH non-condensing

Temperature stability

< 0.02% of reading or 2µV/°C (1µV/°F)

Front face

IP65 (NEMA3), case rear IP20

EMC

Emissions

Meets requirements of EN50081-2

Immunity

Meets requirements of EN50082-2

Design and manufacturing standards

CE mark

Safety standards

EN61010 – 1

C22.2 No. 1010

UL 310 – 1

FM 3810

SS/C150 Issue 9



NOTES



Customer Support

We provide a comprehensive after sales service via our Worldwide Service Organization. Contact one of the following offices for details on your nearest Service and Repair Centre.

**Instrumentation
Systems & Services Ltd**
 PO Box 1 • Ilkley • West Yorkshire • LS29 8EU
 Phone: 01943 602001 • Fax: 01943 816796
 Website: www.issltd.co.uk • Email: sales@issltd.co.uk

Client Warranty

Prior to installation, the equipment referred to in this manual must be stored in a clean, dry environment, in accordance with the Company's published specification. Periodic checks must be made on the equipment's condition.

In the event of a failure under warranty, the following documentation must be provided as substantiation:

1. A listing evidencing process operation and alarm logs at time of failure.
2. Copies of all operating and maintenance records relating to the alleged faulty unit.

CUSTOMER SETUP LOG



LEVEL 1	LEVEL 2
Code	R 1xx
	R 2xx
	R 3xx
	xxxxxx
	t-GO
	SEctot
	PrESEt
	PrEdEt
	R xxxx
	H xxxx
	L xxxx
	QAdJ

Instrument Serial Number: _____

Product Code: C 1 5 0 / _ _ _ _ / _ _ _ _



CUSTOMER CONFIGURATION LOG



LEVEL3		LEVEL4
R 1KCO	A _ B _ C _ D _	ENG HI _ _ _ _
E 0000	E _ F _ G _ H _	ENG LO _ _ _ _
J 0000	J _ K _ L _ N _	rEE HI _ _ _ _
P 0000	P _ R _ S _ T _	rEE LO _ _ _ _
		CNt HI _ _ _ _
		CUTOFF _ _ _ _
		PASS-d _ _ _ _
		Addr. _ _

ABB has Sales & Customer Support expertise in over 100 countries worldwide

The Company's policy is one of continuous product improvement and the right is reserved to modify the information contained herein without notice.

Printed in UK (07.05)

© ABB 2005

ABB

Distributed by



PO Box 1 • Ilkley • West Yorkshire • LS29 8EU
Phone: 01943 602001 • Fax: 01943 816796
Website: www.issltd.co.uk • Email: sales@issltd.co.uk

Instrumentation Systems & Services Ltd



Tel: (01943) 602001- WWW.ISSLTD.CO.UK - Fax: (01943) 816796

